

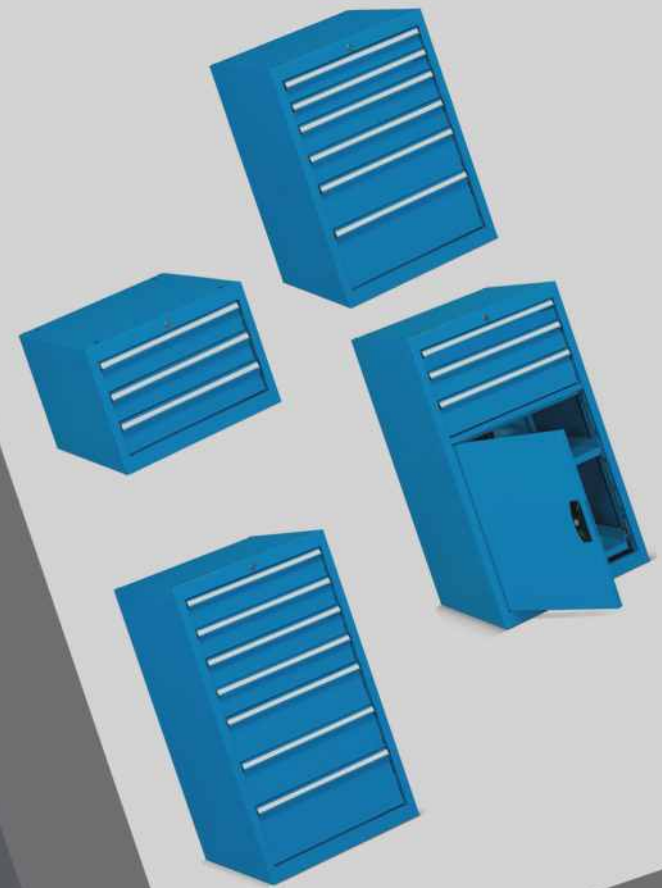

rk steel smith
defining workspace



575MM WIDE TOOL CABINET
PRODUCT RANGE

2018



Tool Cabinet 06
575 W. X 400 H.



Tool Cabinet 07
575 W. X 800 H.



Tool Cabinet 08
575 W. X 800 H.



Tool Cabinet 09
575 W. X 800 H.



Tool Cabinet 10
575 W. X 800 H.



Tool Cabinet 11
575 W. X 1000 H.



Tool Cabinet 12
575 W. X 1000 H.



Tool Cabinet 13
575 W. X 1000 H.

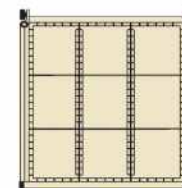

Tool Cabinet 14
Drawer Layout

Standard Depth Series 'S' = 600mm



Tool Cabinet 15
Drawer Layout

Deep Depth Series 'D' = 725mm



Colour — 16

The factory is equipped with latest and modern machinery. For easy and fast movement of raw materials and finished goods suitable overhead crane railings and moving trolley systems are laid in the factory.

There are following main departments in production:

- Production Planning
- Press Shop
- Tool Room
- Assembly department for various products
- 7 Tank Pre-treatment Plant
- Powder coating & Liquid Painting Booth with baking oven
- Baking Oven
- Fitting
- Quality Inspection
- Packing
- Scheduling & despatching

Process of Manufacture :

100% Galvanised steel body are received in press shop where de-coiling and sheet leveling are done. After sheet leveling sheets are cut to require sizes. The cut size sheets are transferred to the power press and notching operation is carried out. After notching operation sheets are transferred to CNC press brakes for doing necessary bending.

Components which are received from press shop are transferred to assembly department for doing spot welding, Co2 welding, ARC welding, Grinding etc.

Assembled components are transfer to pre-treatment plant for treating in 7 tank for degrees, zinc, phosphating and passivation.

Material received from pre-treatment department are immediately powder coated in the dust free painting booth and then the articles are put inside a baking oven at a temperature of 180°C for about 20 minutes.

Then the painted items are sent to the fitting department for necessary fitment of necessary accessories and afterwards final inspection is carried out before packing the goods.

Material: (Housing)

- Housing 1.2mm thk.
- Vertical pillar 2mm thk.
- Horizontal support 2mm thk.
- Cross member 2mm thk.
- Forklift Base 2mm thk.

Material: (Drawer)

- Drawer 1.2mm thk.
- Drawer front face 2mm thk.
- Partition 1.2mm thk.
- Partition slotting strip 0.8mm thk. (Spot weld with Partition 1.2mm thk.)
- Divider 1.2mm thk.
- Drawer pull handle 1.2mm thk.

Material: (Slider)

- (1) Slider 3.0mm thk. with ZZ ball bearing (65 kg.)
600mm depth cabinet
- (2) Slider 3.0mm thk. with ZZ ball bearing (85 kg.)
725mm depth cabinet
- (3) Slider 4.0mm thk. with ZZ ball bearing (200 kg.)
725mm depth cabinet

The technical data contained in this catalogue is approximate. R.K. Steel Smith reserves the right to make any modifications it sees fit to improve the performance and appearance of products. The manufacturer is not liable for any printing errors.

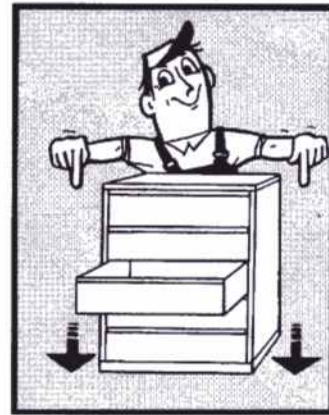

1 Any free-standing drawer cabinet must be fastened to the floor.



2 Cabinets in a row should be bolted together through the sidewalls. The end walls should be fastened to the floor (see #3 side). For the side-to-side bolt kit.

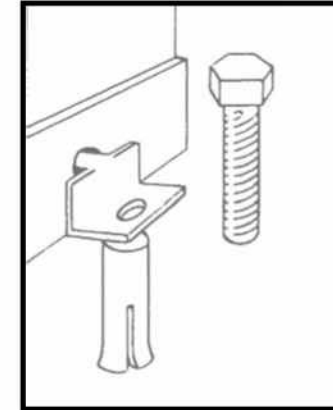

3 For fork truck base or frame base, insert angle piece into hole in bottom. For the floor bolt kit.

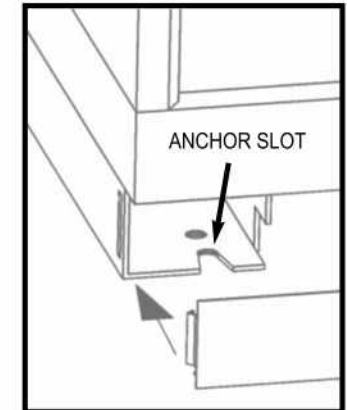

4 Alternate anchoring for cabinets with fork truck base: properly anchor base to floor at front and back using the slots indicated.

- Properly position rear anchors and bolts (customer-supplied), allowing enough clearance to slide the cabinet into position.

- Install front anchors.

CAUTION

ALWAYS BOLT CABINETS SIDE-TO-SIDE OR ANCHOR TO THE FLOOR BEFORE LOADING TO PREVENT CABINET TIPPING.

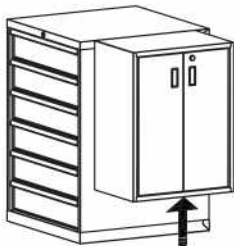

ALWAYS SUPPORT SIDE-MOUNTED CABINETS BEFORE REMOVING DRAWERS TO PREVENT CABINET TIPPING.

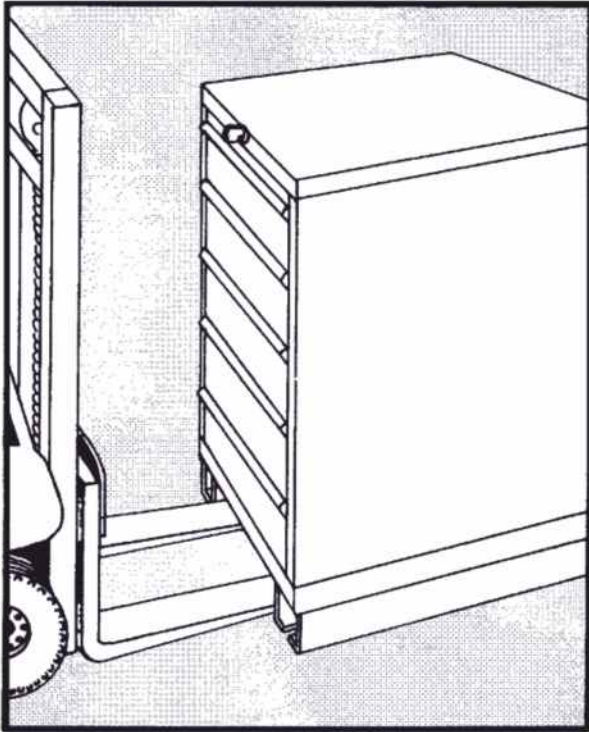

All drawer cabinets should be locked while moving.

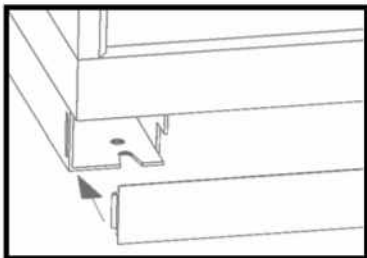

Base cover plate easily snaps on and off to allow for pick-up by fork or pallet truck.

⚠ CAUTION



Do not step into an open drawer.



Do not sit on an open drawer.



Open only one drawer at a time.



The load capacity per drawer (as shown in the catalog) is designed for evenly distributed loads.



Do not drop any heavy loads into a drawer.



All cabinets should be secured to prevent tipping.

Standard Depth Series 'S'= 600mm

Technical Detail:

- (1) Overall Dimension: 575mm W. X 600mm D. X 400mm H.
- (2) Each drawer load cap.: 'S' 65kg.
- (3) Drawer Normal Extension: 80%
- (4) Usable drawer dimensions : 450mm W. x 450mm D. 'S' Depth Cabinet
- (5) **Manufacturing & Materials Details: Page-03**
- (6) Standard: Plain Drawer **Option: Drawers interior- 'S' Page-14**

Deep Depth Series 'D'= 725mm

Technical Detail:

- (1) Overall Dimension: 575mm W. X 725mm D. X 400mm H.
- (2) Each drawer load cap.: 'D' 85kg.
- (3) Drawer Normal Extension: 80%
- (4) Usable drawer dimensions : 450mm W. x 600mm D. 'D' Depth Cabinet
- (5) **Manufacturing & Materials Details: Page-03**
- (6) Standard: Plain Drawer **Option: Drawers interior- 'D' Page-15**

Option:
Forklift Base 100mm H.
(Easy Relocation)



Minimum order qty. - 05no.

Model no.:	Cabinet Size:			Drawer configuration:
	wide	depth	height	
RK TC 575 600D-01	575	600	400	100X3 Drawers
RK TC 575 725D-01	575	725	400	100X3 Drawers
RK TC 575 600D-02	575	600	400	150X2 Drawers
RK TC 575 725D-02	575	725	400	150X2 Drawers
RK TC 575 600D-03	575	600	400	75X2,150X1 Drawers
RK TC 575 725D-03	575	725	400	75X2,150X1 Drawers
RK TC 575 600D-04	575	600	400	100X2, 200X1 Drawers
RK TC 575 725D-04	575	725	400	100X2, 200X1 Drawers
RK TC 575 600D-05	575	600	400	75X4 Drawers
RK TC 575 725D-05	575	725	400	75X4 Drawers

To anchor Cabinet



The cabinets must be secured to the floor or to the wall.

You should not open another drawer while one is opened.

Standard Depth Series 'S'= 600mm

Technical Detail:

- (1) Overall Dimension: 575mm W. X 600mm D. X 400mm H.
- (2) Each drawer load cap.: 'S' 65kg.
- (3) Drawer Normal Extension: 80%
- (4) Usable drawer dimensions : 450mm W. x 450mm D. 'S' Depth Cabinet
- (5) **Manufacturing & Materials Details: Page-03**
- (6) Standard: Plain Drawer **Option: Drawers interior- 'S' Page-14**

Deep Depth Series 'D'= 725mm

Technical Detail:

- (1) Overall Dimension: 575mm W. X 725mm D. X 400mm H.
- (2) Each drawer load cap.: 'D' 85kg.
- (3) Drawer Normal Extension: 80%
- (4) Usable drawer dimensions : 450mm W. x 600mm D. 'D' Depth Cabinet
- (5) **Manufacturing & Materials Details: Page-03**
- (6) Standard: Plain Drawer **Option: Drawers interior- 'D' Page-15**

Option:
Forklift Base 100mm H.
(Easy Relocation)



Minimum order qty. - 03no.

Model no.:	Cabinet Size:			Drawer configuration:
	wide	depth	height	
RK TC 575 600D-06	575	600	800	100X4, 150X2 Drawers
RK TC 575 725D-06	575	725	800	100X4, 150X2 Drawers
RK TC 575 600D-07	575	600	800	75X2, 100X4, 150X1 Drawers
RK TC 575 725D-07	575	725	800	75X2, 100X4, 150X1 Drawers
RK TC 575 600D-08	575	600	800	100X7 Drawers
RK TC 575 725D-08	575	725	800	100X7 Drawers
RK TC 575 600D-09	575	600	800	100X2, 200X1, 300X1 Drawers
RK TC 575 725D-09	575	725	800	100X2, 200X1, 300X1 Drawers
RK TC 575 600D-10	575	600	800	75X2, 100X2, 150X1, 200X1 Drawers
RK TC 575 725D-10	575	725	800	75X2, 100X2, 150X1, 200X1 Drawers

To anchor Cabinet



The cabinets must be secured to the floor or to the wall.

You should not open another drawer while one is opened.

Standard Depth Series 'S'= 600mm

Technical Detail:

- (1) Overall Dimension: 575mm W. X 600mm D. X 400mm H.
- (2) Each drawer load cap.: 'S' 65kg.
- (3) Drawer Normal Extension: 80%
- (4) Usable drawer dimensions : 450mm W. x 450mm D. 'S' Depth Cabinet
- (5) **Manufacturing & Materials Details: Page-03**
- (6) Standard: Plain Drawer **Option: Drawers interior- 'S' Page-14**

Deep Depth Series 'D'= 725mm

Technical Detail:

- (1) Overall Dimension: 575mm W. X 725mm D. X 400mm H.
- (2) Each drawer load cap.: 'D' 85kg.
- (3) Drawer Normal Extension: 80%
- (4) Usable drawer dimensions : 450mm W. x 600mm D. 'D' Depth Cabinet
- (5) **Manufacturing & Materials Details: Page-03**
- (6) Standard: Plain Drawer **Option: Drawers interior- 'D' Page-15**

Option:
Forklift Base 100mm H.
(Easy Relocation)



Minimum order qty. - 03no.

Model no.:	Cabinet Size:			Drawer configuration:
	wide	depth	height	
RK TC 575 600D-11	575	600	800	75X1 Drawers 575mm H. Compt. with shelf & door
RK TC 575 725D-11	575	725	800	75X1 Drawers 575mm H. Compt. with shelf & door
RK TC 575 600D-12	575	600	800	100X1 Drawers 550mm H. Compt. with shelf & door
RK TC 575 725D-12	575	725	800	100X1 Drawers 550mm H. Compt. with shelf & door
RK TC 575 600D-13	575	600	800	150X1 Drawers 500mm H. Compt. with shelf & door
RK TC 575 725D-13	575	725	800	150X1 Drawers 500mm H. Compt. with shelf & door
RK TC 575 600D-14	575	600	800	175X1 Drawers 475mm H. Compt. with door & no shelf
RK TC 575 725D-14	575	725	800	175X1 Drawers 475mm H. Compt. with door & no shelf
RK TC 575 600D-15	575	600	800	200X1 Drawers 450mm H. Compt. with door & no shelf
RK TC 575 725D-15	575	725	800	200X1 Drawers 450mm H. Compt. with door & no shelf

To anchor Cabinet



The cabinets must be secured to the floor or to the wall.

You should not open another drawer while one is opened.

Standard Depth Series 'S'= 600mm

Technical Detail:

- (1) Overall Dimension: 575mm W. X 600mm D. X 400mm H.
- (2) Each drawer load cap.: 'S' 65kg.
- (3) Drawer Normal Extension: 80%
- (4) Usable drawer dimensions : 450mm W. x 450mm D. 'S' Depth Cabinet
- (5) **Manufacturing & Materials Details: Page-03**
- (6) Standard: **Plain Drawer** **Option: Drawers interior- 'S' Page-14**

Deep Depth Series 'D'= 725mm

Technical Detail:

- (1) Overall Dimension: 575mm W. X 725mm D. X 400mm H.
- (2) Each drawer load cap.: 'D' 85kg.
- (3) Drawer Normal Extension: 80%
- (4) Usable drawer dimensions : 450mm W. x 600mm D. 'D' Depth Cabinet
- (5) **Manufacturing & Materials Details: Page-03**
- (6) Standard: **Plain Drawer** **Option: Drawers interior- 'D' Page-15**

Option:
Forklift Base 100mm H.
(Easy Relocation) 



Model no.:	Cabinet Size:			Drawer configuration:
	wide	depth	height	
RK TC 575 600D-16	575	600	800	75X2 Drawers 500mm H. Compt. with shelf & door
RK TC 575 725D-16	575	725	800	75X2 Drawers 500mm H. Compt. with shelf & door
RK TC 575 600D-17	575	600	800	100X2 Drawers 450mm H. Compt. with door & no shelf
RK TC 575 725D-17	575	725	800	100X2 Drawers 450mm H. Compt. with door & no shelf
RK TC 575 600D-18	575	600	800	75X1, 125X1 Drawers 400mm H. Compt. with door & no shelf
RK TC 575 725D-18	575	725	800	75X1, 125X1 Drawers 400mm H. Compt. with door & no shelf

Minimum order qty. - 03no.

To anchor Cabinet



The cabinets must be secured to the floor or to the wall.

You should not open another drawer while one is opened.

Standard Depth Series 'S'= 600mm

Technical Detail:

- (1) Overall Dimension: 575mm W. X 600mm D. X 400mm H.
- (2) Each drawer load cap.: 'S' 65kg.
- (3) Drawer Normal Extension: 80%
- (4) Usable drawer dimensions : 450mm W. x 450mm D. 'S' Depth Cabinet
- (5) **Manufacturing & Materials Details: Page-03**
- (6) Standard: Plain Drawer **Option: Drawers interior- 'S' Page-14**

Deep Depth Series 'D'= 725mm

Technical Detail:

- (1) Overall Dimension: 575mm W. X 725mm D. X 400mm H.
- (2) Each drawer load cap.: 'D' 85kg.
- (3) Drawer Normal Extension: 80%
- (4) Usable drawer dimensions : 450mm W. x 600mm D. 'D' Depth Cabinet
- (5) **Manufacturing & Materials Details: Page-03**
- (6) Standard: Plain Drawer **Option: Drawers interior- 'D' Page-15**

Option:
Forklift Base 100mm H.
(Easy Relocation) 



Minimum order qty. - 03no.

Model no.:	Cabinet Size:			Drawer configuration:
	wide	depth	height	
RK TC 575 600D-19	575	600	800	100X3 Drawers 425mm H. Compt. with door & no shelf
RK TC 575 725D-19	575	725	800	100X3 Drawers 425mm H. Compt. with door & no shelf
RK TC 575 600D-20	575	600	800	150X2 Drawers 425mm H. Compt. with door & no shelf
RK TC 575 725D-20	575	725	800	150X2 Drawers 425mm H. Compt. with door & no shelf
RK TC 575 600D-21	575	600	800	75X2, 150X1 Drawers 425mm H. Compt. with door & no shelf
RK TC 575 725D-21	575	725	800	75X2, 150X1 Drawers 425mm H. Compt. with door & no shelf
RK TC 575 600D-22	575	600	800	75X4 Drawers 425mm H. Compt. with door & no shelf
RK TC 575 725D-22	575	725	800	75X4 Drawers 425mm H. Compt. with door & no shelf
RK TC 575 600D-23	575	600	800	100X1, 200X1 Drawers 425mm H. Compt. with door & no shelf
RK TC 575 725D-23	575	725	800	100X1, 200X1 Drawers 425mm H. Compt. with door & no shelf



To anchor Cabinet

The cabinets must be secured to the floor or to the wall.

You should not open another drawer while one is opened.

Standard Depth Series 'S'= 600mm

Technical Detail:

- (1) Overall Dimension: 575mm W. X 600mm D. X 400mm H.
- (2) Each drawer load cap.: 'S' 65kg.
- (3) Drawer Normal Extension: 80%
- (4) Usable drawer dimensions : 450mm W. x 450mm D. 'S' Depth Cabinet
- (5) **Manufacturing & Materials Details: Page-03**
- (6) Standard: Plain Drawer **Option: Drawers interior- 'S' Page-14**

Deep Depth Series 'D'= 725mm

Technical Detail:

- (1) Overall Dimension: 575mm W. X 725mm D. X 400mm H.
- (2) Each drawer load cap.: 'D' 85kg.
- (3) Drawer Normal Extension: 80%
- (4) Usable drawer dimensions : 450mm W. x 600mm D. 'D' Depth Cabinet
- (5) **Manufacturing & Materials Details: Page-03**
- (6) Standard: Plain Drawer **Option: Drawers interior- 'D' Page-15**

Option:
Forklift Base 100mm H.
(Easy Relocation)



Model no.:	Cabinet Size:			Drawer configuration:
	wide	depth	height	
RK TC 575 600D-24	575	600	1000	75X12 Drawers
RK TC 575 725D-24	575	725	1000	75X12 Drawers
RK TC 575 600D-25	575	600	1000	100X9 Drawers
RK TC 575 725D-25	575	725	1000	100X9 Drawers
RK TC 575 600D-26	575	600	1000	150X6 Drawers
RK TC 575 725D-26	575	725	1000	150X6 Drawers
RK TC 575 600D-27	575	600	1000	100X4, 150X2, 200X1 Drawers
RK TC 575 725D-27	575	725	1000	100X4, 150X2, 200X1 Drawers
RK TC 575 600D-28	575	600	1000	75X2, 100X4, 150X1, 200X1 Drawers
RK TC 575 725D-28	575	725	1000	75X2, 100X4, 150X1, 200X1 Drawers

To anchor Cabinet



The cabinets must be secured to the floor or to the wall.

You should not open another drawer while one is opened.

Standard Depth Series 'S'= 600mm

Technical Detail:

- (1) Overall Dimension: 575mm W. X 600mm D. X 400mm H.
- (2) Each drawer load cap.: 'S' 65kg.
- (3) Drawer Normal Extension: 80%
- (4) Usable drawer dimensions : 450mm W. x 450mm D. 'S' Depth Cabinet
- (5) **Manufacturing & Materials Details: Page-03**
- (6) Standard: Plain Drawer **Option: Drawers interior- 'S' Page-14**

Deep Depth Series 'D'= 725mm

Technical Detail:

- (1) Overall Dimension: 575mm W. X 725mm D. X 400mm H.
- (2) Each drawer load cap.: 'D' 85kg.
- (3) Drawer Normal Extension: 80%
- (4) Usable drawer dimensions : 450mm W. x 600mm D. 'D' Depth Cabinet
- (5) **Manufacturing & Materials Details: Page-03**
- (6) Standard: Plain Drawer **Option: Drawers interior- 'D' Page-15**

Option:
Forklift Base 100mm H.
(Easy Relocation)



Minimum order qty. - 02no.

Model no.:	Cabinet Size:			Drawer configuration:
	wide	depth	height	
RK TC 575 600D-29	575	600	1000	75X3 Drawers 625mm H. Compt. with shelf & door
RK TC 575 725D-29	575	725	1000	75X3 Drawers 625mm H. Compt. with shelf & door
RK TC 575 600D-30	575	600	1000	100X3 Drawers 550mm H. Compt. with shelf & door
RK TC 575 725D-30	575	725	1000	100X3 Drawers 550mm H. Compt. with shelf & door
RK TC 575 600D-31	575	600	1000	75X2, 150X1 Drawers 550mm H. Compt. with shelf & door
RK TC 575 725D-31	575	725	1000	75X2, 150X1 Drawers 550mm H. Compt. with shelf & door
RK TC 575 600D-32	575	600	1000	75X1, 100X1, 150X1 Drawers 525mm H. Compt. with shelf & door
RK TC 575 725D-32	575	725	1000	75X1, 100X1, 150X1 Drawers 525mm H. Compt. with shelf & door
RK TC 575 600D-32	575	600	1000	100X2, 150X1 Drawers 550mm H. Compt. with shelf & door
RK TC 575 725D-32	575	725	1000	100X2, 150X1 Drawers 550mm H. Compt. with shelf & door



To anchor Cabinet

The cabinets must be secured to the floor or to the wall.

You should not open another drawer while one is opened.

Standard Depth Series 'S'= 600mm

Technical Detail:

- (1) Overall Dimension: 575mm W. X 600mm D. X 400mm H.
- (2) Each drawer load cap.: 'S' 65kg.
- (3) Drawer Normal Extension: 80%
- (4) Usable drawer dimensions : 450mm W. x 450mm D. 'S' Depth Cabinet
- (5) **Manufacturing & Materials Details: Page-03**
- (6) Standard: Plain Drawer **Option: Drawers interior- 'S' Page-14**

Deep Depth Series 'D'= 725mm

Technical Detail:

- (1) Overall Dimension: 575mm W. X 725mm D. X 400mm H.
- (2) Each drawer load cap.: 'D' 85kg.
- (3) Drawer Normal Extension: 80%
- (4) Usable drawer dimensions : 450mm W. x 600mm D. 'D' Depth Cabinet
- (5) **Manufacturing & Materials Details: Page-03**
- (6) Standard: Plain Drawer **Option: Drawers interior- 'D' Page-15**

Option:
Forklift Base 100mm H.
(Easy Relocation)



Minimum order qty. - 02no.

Model no.:	Cabinet Size:			Drawer configuration:
	wide	depth	height	
RK TC 575 600D-33	575	600	1000	75X5 Drawers 475mm H. Compt. with door & no shelf
RK TC 575 725D-33	575	725	1000	75X5 Drawers 475mm H. Compt. with door & no shelf
RK TC 575 600D-34	575	600	1000	100X5 Drawers 350mm H. Compt. with door & no shelf
RK TC 575 725D-34	575	725	1000	100X5 Drawers 350mm H. Compt. with door & no shelf
RK TC 575 600D-35	575	600	1000	100X3, 150X2 Drawers 300mm H. Compt. with door & no shelf
RK TC 575 725D-35	575	725	1000	100X3, 150X2 Drawers 300mm H. Compt. with door & no shelf
RK TC 575 600D-36	575	600	1000	75X2, 100X2, 150X1 Drawers 350mm H. Compt. with door & no shelf
RK TC 575 725D-36	575	725	1000	75X2, 100X2, 150X1 Drawers 350mm H. Compt. with door & no shelf

To anchor Cabinet



The cabinets must be secured to the floor or to the wall.

You should not open another drawer while one is opened.

Standard Depth Series 'S' = 600mm

Drawers Layout for 75 to 150mm H. Drawers (150mm onward plain drawers)

RK TC DR 575 600-1

450W X 450D
75mm to 300mm
drawers



RK TC DR 575 600-2

450W X 450D
75mm to 300mm
drawers



RK TC DR 575 600-3

Each 150W X 450D-4no.
compartment
75/100/150 drawers

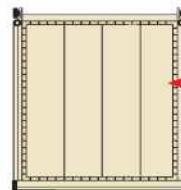

Long tool
storage

RK TC DR 575 600-4

Each 225W X 150D-6no.
compartment
75/100/150 drawers

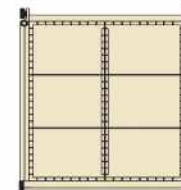

RK TC DR 575 600-5

Each 150W X 150D-9no.
compartment
75/100/150 drawers

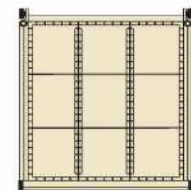

Plastic container only for 75 & 100mm H. Drawers



45mm H.
75mm Drawers



75mm H.
100mm Drawers

RK TC DR 575 600-P1

75/100 drawers

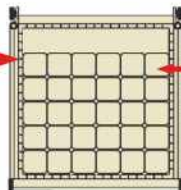

75W.X75D.X45/75H.
30no.
Plastic container
in each drawer

RK TC DR 575 600-P2

75/100 drawers

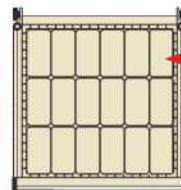

75W.X150D.X45/75H.
18no.
Plastic container
in each drawer

RK TC DR 575 600-P3

75/100 drawers

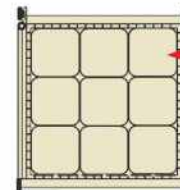

150W.X150D.X45/75H.
09no.
Plastic container
in each drawer

RK TC DR 575 600-P4

75/100 drawers

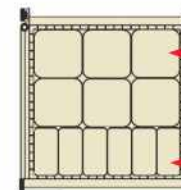

150W.X150D.X45/75H.
06no.
Plastic container
in each drawer
75W.X150D.X45/75H.
06no.
Plastic container
in each drawer

Deep Depth Series 'D'= 725mm

Drawers Layout for 75 to 150mm H. Drawers (150mm onward plain drawers)

RK TC DR 575 725-1

450W X 600D
75mm to 300mm
drawers



RK TC DR 575 725-2

450W X 600D
75mm to 300mm
drawers



RK TC DR 575 725-3

Each 150W X 600D-4no.
compartment
75/100/150 drawers

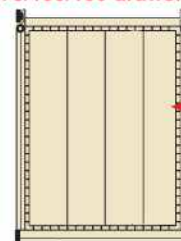

Long tool
storage

RK TC DR 575 725-4

Each 225W X 200D-6no.
compartment
75/100/150 drawers

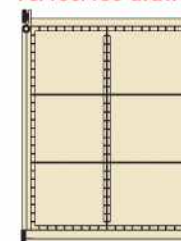

RK TC DR 575 725-5

Each 150W X 200D-9no.
compartment
75/100/150 drawers

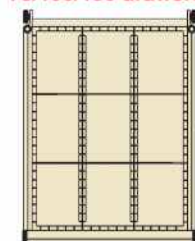

Plastic container only for 75 & 100mm H. Drawers



45mm H.
75mm Drawers



75mm H.
100mm Drawers

RK TC DR 575 725-P1

75/100 drawers

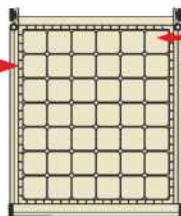

75W.X75D.X45/75H.
42no.
Plastic container
in each drawer

RK TC DR 575 725-P2

75/100 drawers

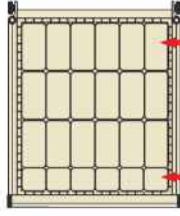

75W.X150D.X45/75H.
18no.
Plastic container
in each drawer

75W.X75D.X45/75H.
06no.
Plastic container
in each drawer

RK TC DR 575 725-P3

75/100 drawers

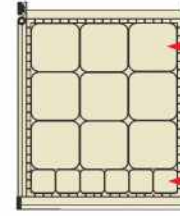

150W.X150D.X45/75H.
09no.
Plastic container
in each drawer

75W.X75D.X45/75H.
06no.
Plastic container
in each drawer

RK TC DR 575 725-P4

75/100 drawers

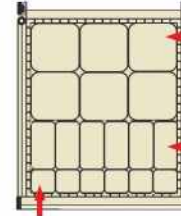

150W.X150D.X45/75H.
06no.
Plastic container
in each drawer

75W.X150D.X45/75H.
06no.
Plastic container
in each drawer

75W.X75D.X45/75H.
06no.
Plastic container
in each drawer

Standard Color option :



AMERICAN BLUE
STRUCTURE FINISH



7035 PALE GREY
STRUCTURE FINISH



DA GREY
STRUCTURE FINISH



PO RED
STRUCTURE FINISH

Assembled components are transfer to pre-treatment plant for treating in 7 tank for degrees, zinc, phosphating and passivation.

Material received from pre-treatment department are immediately powder coated in the dust free painting booth and then the articles are put inside a baking oven at a temperature of 180° C for about 20 minutes.



rk steel smith
defining workspace



Plot- B/32 (Part-2) Bileshwar Indl. Estate,
Opp. G.V.M.M.,
Odhav-Kathwada Road,
Ahmedabad - 382415
Gujarat (INDIA).



+91 94 281 35 100
+91 98 253 00 059



rksteelsmith@gmail.com
info@rksteelsmith.com
sales@rksteelsmith.com



www.rksteelsmith.com