

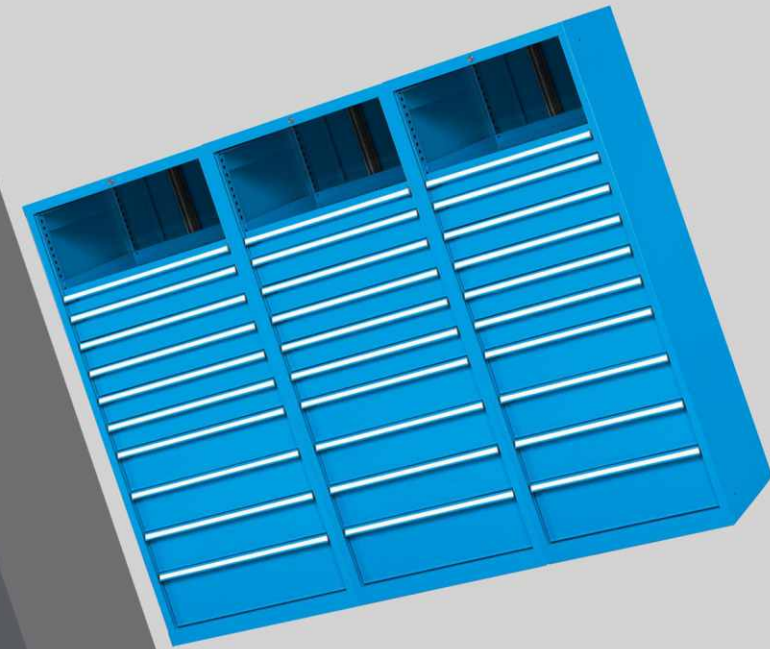

**rk steel smith**  
defining workspace



# 725MM WALL-STORAGE CABINET

PRODUCT RANGE

2018



**Wall Storage Cabinet**  
1450 W. X 1850 H.

06 & 07



**Wall Storage Cabinet**  
1450 W. X 1850 H.

08 & 10

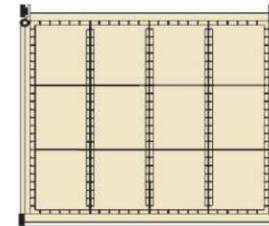

**Drawer Layout**

11

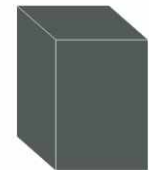
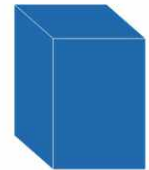

**Colour — 12**

The factory is equipped with latest and modern machinery. For easy and fast movement of raw materials and finished goods suitable overhead crane railings and moving trolley systems are laid in the factory.

There are following main departments in production:

- Production Planning
- Press Shop
- Tool Room
- Assembly department for various products
- 7 Tank Pre-treatment Plant
- Powder coating & Liquid Painting Booth with baking oven
- Baking Oven
- Fitting
- Quality Inspection
- Packing
- Scheduling & despatching

## Process of Manufacture :

**100% Galvanised steel body** are received in press shop where de-coiling and sheet leveling are done. After sheet leveling sheets are cut to require sizes. The cut size sheets are transferred to the power press and notching operation is carried out. After notching operation sheets are transferred to CNC press brakes for doing necessary bending.

Components which are received from press shop are transferred to assembly department for doing spot welding, Co2 welding, ARC welding, Grinding etc.

Assembled components are transfer to pre-treatment plant for treating in 7 tank for degrees, zinc, phosphating and passivation.

Material received from pre-treatment department are immediately powder coated in the dust free painting booth and then the articles are put inside a baking oven at a temperature of 180°C for about 20 minutes.

Then the painted items are sent to the fitting department for necessary fitment of necessary accessories and afterwards final inspection is carried out before packing the goods.

### Material: (Housing)

- Housing 1.2mm thk.
- Vertical pillar 2mm thk.
- Horizontal support 2mm thk.
- Cross member 2mm thk.
- Forklift Base 2mm thk.

### Material: (Drawer)

- Drawer 1.2mm thk.
- Drawer front face 2mm thk.
- Partition 1.2mm thk.
- Partition slotting strip 0.8mm thk. (Spot weld with Partition 1.2mm thk.)
- Divider 1.2mm thk.
- Drawer pull handle 1.2mm thk.

### Material: (Slider)

- (1) Slider 3.0mm thk. with ZZ ball bearing (85 kg.)  
**725mm depth cabinet**
- (2) Slider 4.0mm thk. with ZZ ball bearing (200 kg.)  
**725mm depth cabinet**

The technical data contained in this catalogue is approximate. R.K. Steel Smith reserves the right to make any modifications it sees fit to improve the performance and appearance of products. The manufacturer is not liable for any printing errors.

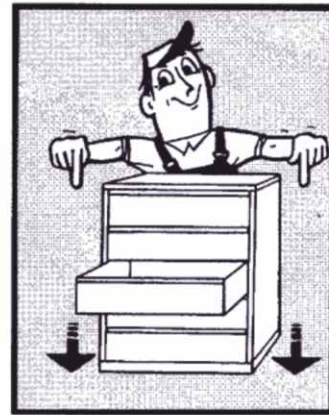

**1** Any free-standing drawer cabinet must be fastened to the floor.



**2** Cabinets in a row should be bolted together through the sidewalls. The end walls should be fastened to the floor (see #3 side). For the side-to-side bolt kit.

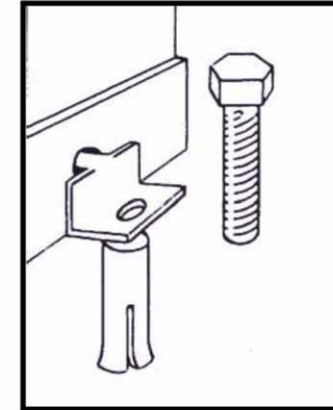

**3** fork truck base or frame base, insert angle piece into hole in bottom. For the floor bolt kit.

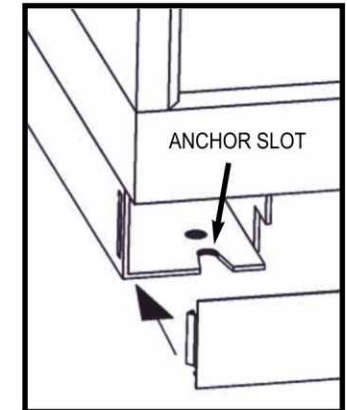

**4** Alternate anchoring for cabinets with fork truck base: properly anchor base to floor at front and back using the slots indicated.

- Properly position rear anchors and bolts (customer-supplied), allowing enough clearance to slide the cabinet into position.

- Install front anchors.

**CAUTION**

**ALWAYS BOLT CABINETS SIDE-TO-SIDE OR ANCHOR TO THE FLOOR BEFORE LOADING TO PREVENT CABINET TIPPING.**

**ALWAYS SUPPORT SIDE-MOUNTED CABINETS BEFORE REMOVING DRAWERS TO PREVENT CABINET TIPPING.**

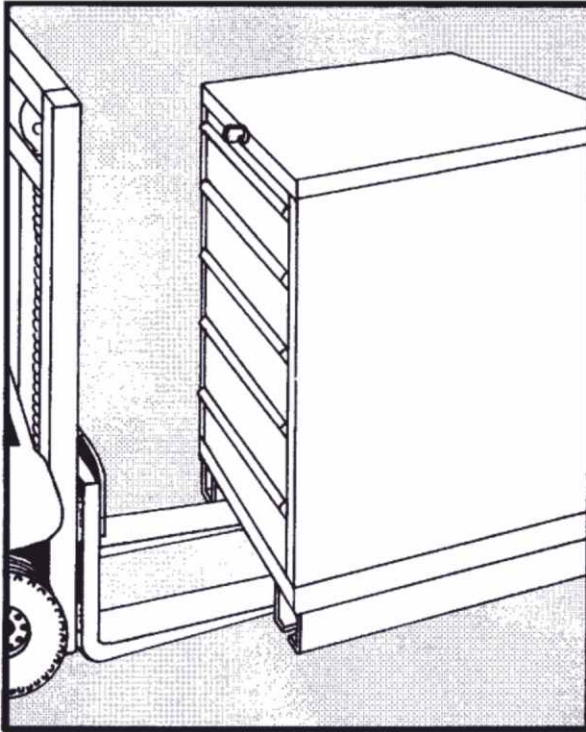

All drawer cabinets should be locked while moving.

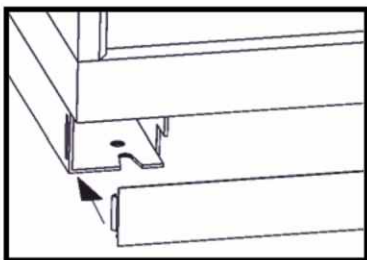

Base cover plate easily snaps on and off to allow for pick-up by fork or pallet truck.

## ⚠ CAUTION



Do not step into an open drawer.



Do not sit on an open drawer.



Open only one drawer at a time.



The load capacity per drawer (as shown in the catalog) is designed for evenly distributed loads.



Do not drop any heavy loads into a drawer.



All cabinets should be secured to prevent tipping.

### Deep Depth Series 'D'= 725mm

#### Technical Detail:

- (1) Overall Dimension: 1450mm W. (725+725) X 725mm D. X 1850mm H.
- (2) Each drawer load cap.: 'D' 85kg.
- (3) Drawer Normal Extension: 80%
- (4) Usable drawer dimensions : 600mm W. x 600mm D. 'D' Depth Cabinet
- (5) **Manufacturing & Materials Details: Page-03**
- (6) Standard: Plain Drawer **Option: Drawers interior- 'D' Page-10**

#### Include:

Forklift Base 100mm H.  
(Easy Relocation)

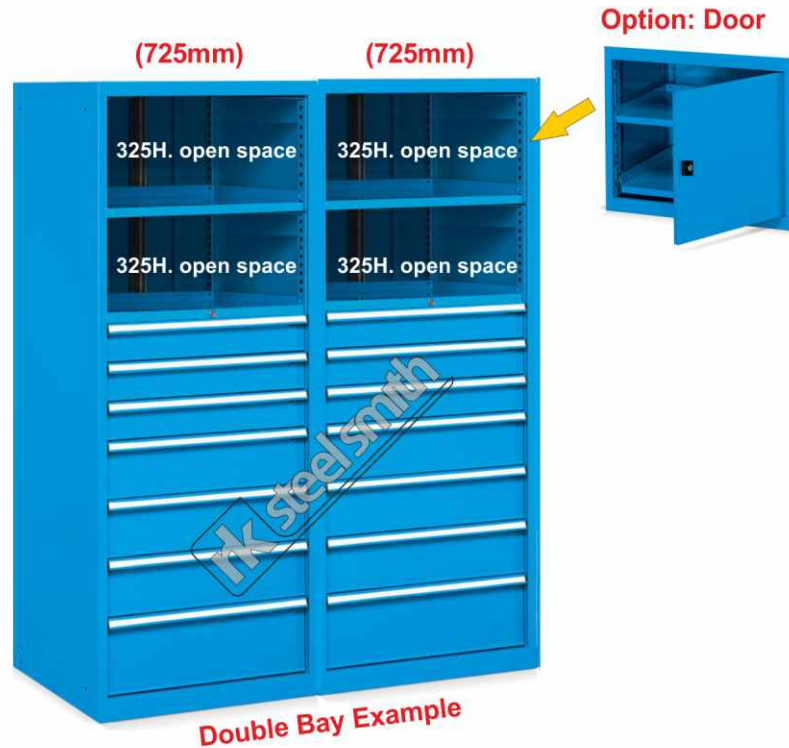

#### Model no.:

#### Cabinet Size:

#### Drawer configuration:

Model no.:	wide	depth	height	Drawer configuration:
RK WALL TC 725D-01	1450	725	1850	75X12 Drawers (each bay)
RK WALL TC 725D-02	1450	725	1850	100X9 Drawers (each bay)
RK WALL TC 725D-03	1450	725	1850	150X6 Drawers (each bay)
RK WALL TC 725D-04	1450	725	1850	100X4, 150X2, 200X1 Drawers (each bay)
RK WALL TC 725D-05	1450	725	1850	75X2, 100X4, 150X1, 200X1 Drawers (each bay)
RK WALL TC 725D-06	1450	725	1850	100X2, 150X2, 200X2 Drawers (each bay)
RK WALL TC 725D-07	1450	725	1850	100X6, 150X2 Drawers (each bay)
RK WALL TC 725D-08	1450	725	1850	100X3, 150X2, 300X1 Drawers (each bay)

To anchor Cabinet



The cabinets must be secured to the floor or to the wall.

You should not open another drawer while one is opened.

### Deep Depth Series 'D'= 725mm

**Technical Detail:**

- (1) Overall Dimension: 1450mm W. (725+725) X 725mm D. X 1850mm H.
- (2) Each drawer load cap.: 'D' 85kg.
- (3) Drawer Normal Extension: 80%
- (4) Usable drawer dimensions : 600mm W. x 600mm D. 'D' Depth Cabinet
- (5) **Manufacturing & Materials Details: Page-03**
- (6) Standard: Plain Drawer **Option: Drawers interior- 'D' Page-10**

**Include:**

Forklift Base 100mm H.  
(Easy Relocation)



**Model no.:**

**Cabinet Size:**

**Drawer configuration:**

Model no.:	wide	depth	height	Drawer configuration:
RK WALL TC 725D-09	1450	725	1850	75X18 Drawers (each bay)
RK WALL TC 725D-10	1450	725	1850	100X14 Drawers (each bay)
RK WALL TC 725D-11	1450	725	1850	150X9 Drawers (each bay)
RK WALL TC 725D-12	1450	725	1850	100X6, 150X5 Drawers (each bay)
RK WALL TC 725D-13	1450	725	1850	75X4, 100X6, 150X3 Drawers (each bay)
RK WALL TC 725D-14	1450	725	1850	75X4, 100X4, 150X3, 200X1 Drawers (each bay)
RK WALL TC 725D-15	1450	725	1850	100X6, 150X1, 200X3 Drawers (each bay)
RK WALL TC 725D-16	1450	725	1850	150X1, 200X6 Drawers (each bay)
RK WALL TC 725D-17	1450	725	1850	100X6, 150X3, 300X1 Drawers (each bay)
RK WALL TC 725D-18	1450	725	1850	150X1, 200X6 Drawers (each bay)

To anchor Cabinet



**The cabinets must be secured to the floor or to the wall.**

**You should not open another drawer while one is opened.**

## Deep Depth Series 'D'= 725mm

### Technical Detail:

- (1) Overall Dimension: 2175mm W. (725+725+725) X 725mm D. X 1850mm H.
- (2) Each drawer load cap.: 'D' 85kg.
- (3) Drawer Normal Extension: 80%
- (4) Usable drawer dimensions : 600mm W. x 600mm D. 'D' Depth Cabinet
- (5) **Manufacturing & Materials Details: Page-03**
- (6) Standard: Plain Drawer **Option: Drawers interior- 'D' Page-10**

### Include:

Forklift Base 100mm H.  
(Easy Relocation)



### Option: Door



### Model no.:

### Cabinet Size:

### Drawer configuration:

Model no.:	wide	depth	height	Drawer configuration:
RK WALL TC 725D-19	2175	725	1850	75X12 Drawers (each bay)
RK WALL TC 725D-20	2175	725	1850	100X9 Drawers (each bay)
RK WALL TC 725D-21	2175	725	1850	150X6 Drawers (each bay)
RK WALL TC 725D-22	2175	725	1850	100X4, 150X2, 200X1 Drawers (each bay)
RK WALL TC 725D-23	2175	725	1850	75X2, 100X4, 150X1, 200X1 Drawers (each bay)
RK WALL TC 725D-24	2175	725	1850	100X2, 150X2, 200X2 Drawers (each bay)
RK WALL TC 725D-25	2175	725	1850	100X6, 150X2 Drawers (each bay)
RK WALL TC 725D-26	2175	725	1850	100X3, 150X2, 300X1 Drawers (each bay)

To anchor Cabinet



**The cabinets must be secured to the floor or to the wall.**

**You should not open another drawer while one is opened.**



## Deep Depth Series 'D'= 725mm

### Technical Detail:

- (1) Overall Dimension: 2175mm W. (725+725+725) X 725mm D. X 1850mm H.
- (2) Each drawer load cap.: 'D' 85kg.
- (3) Drawer Normal Extension: 80%
- (4) Usable drawer dimensions : 600mm W. x 600mm D. 'D' Depth Cabinet
- (5) **Manufacturing & Materials Details: Page-03**
- (6) Standard: Plain Drawer **Option: Drawers interior- 'D' Page-10**

### Include:

Forklift Base 100mm H.  
(Easy Relocation)



### Option: Door



### Model no.:

### Cabinet Size:

### Drawer configuration:

Model no.:	wide	depth	height	Drawer configuration:
RK WALL TC 725D-27	2175	725	1850	75X18 Drawers (each bay)
RK WALL TC 725D-28	2175	725	1850	100X14 Drawers (each bay)
RK WALL TC 725D-29	2175	725	1850	150X9 Drawers (each bay)
RK WALL TC 725D-30	2175	725	1850	100X6, 150X5 Drawers (each bay)
RK WALL TC 725D-31	2175	725	1850	75X4, 100X6, 150X3 Drawers (each bay)
RK WALL TC 725D-32	2175	725	1850	75X4, 100X4, 150X3, 200X1 Drawers (each bay)
RK WALL TC 725D-33	2175	725	1850	100X6, 150X1, 200X3 Drawers (each bay)
RK WALL TC 725D-34	2175	725	1850	150X1, 200X6 Drawers (each bay)
RK WALL TC 725D-35	2175	725	1850	100X6, 150X3, 300X1 Drawers (each bay)
RK WALL TC 725D-36	2175	725	1850	150X1, 200X6 Drawers (each bay)

To anchor Cabinet





**The cabinets must be secured to the floor or to the wall.**

**You should not open another drawer while one is opened.**

**Deep Depth Series 'D'= 725mm**

**Drawers Layout for 75 to 150mm H. Drawers (150mm onward plain drawers)**

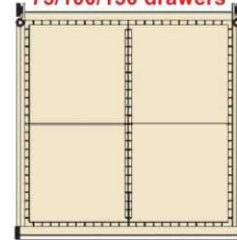
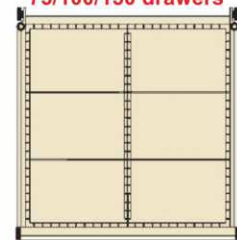
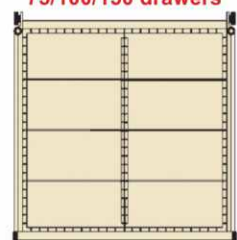
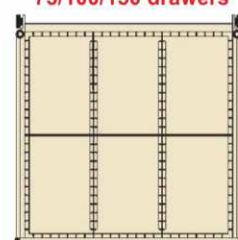
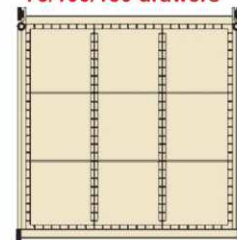
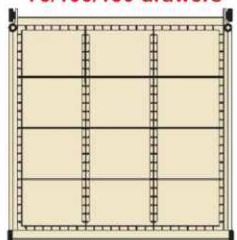
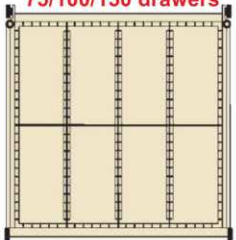
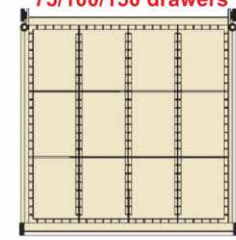
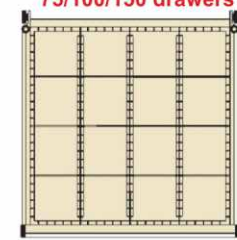
<p><b>RK TC DR 725 725-1</b> 600W X 600D 75mm to 300mm drawers Plain Drawer</p> 	<p><b>RK TC DR 725 725-2</b> 600W X 600D 75mm to 300mm drawers 450W X 600D Plain Drawer with 4mm rubber sheet</p> 	<p><b>RK TC DR 725 725-3</b> 300W X 300D-4no. Each compartment 75/100/150 drawers</p> 	<p><b>RK TC DR 725 725-4</b> 300W X 200D-6no. Each compartment 75/100/150 drawers</p> 	<p><b>RK TC DR 725 725-5</b> 300W X 150D-8no. Each compartment 75/100/150 drawers</p> 	<p><b>RK TC DR 725 725-6</b> 200W X 300D-6no. Each compartment 75/100/150 drawers</p> 
<p><b>RK TC DR 725 725-7</b> 200W X 200D-9no. Each compartment 75/100/150 drawers</p> 	<p><b>RK TC DR 725 725-8</b> 200W X 150D-12no. Each compartment 75/100/150 drawers</p> 	<p><b>RK TC DR 725 725-9</b> 150W X 300D-8no. Each compartment 75/100/150 drawers</p> 	<p><b>RK TC DR 725 725-10</b> 150W X 200D-12no. Each compartment 75/100/150 drawers</p> 	<p><b>RK TC DR 725 725-12</b> 150W X 150D-16no. Each compartment 75/100/150 drawers</p> 	

**Plastic container only for 75 & 100mm H. Drawers**

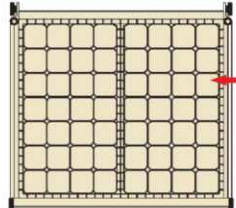
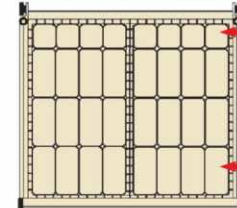
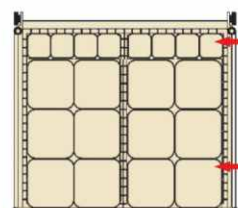

<p><b>RK TC DR 725 725-P1</b> 75/100 drawers 75W.X75D.X45/75H. 56no. Plastic container in each drawer</p> 	<p><b>RK TC DR 725 725-P2</b> 75/100 drawers 75W.X75D.X45/75H. 08no. Plastic container in each drawer 75W.X150D.X45/75H. 24no. Plastic container in each drawer</p> 	<p><b>RK TC DR 725 725-P3</b> 75/100 drawers 75W.X75D.X45/75H. 08no. Plastic container in each drawer 150W.X150D.X45/75H. 12no. Plastic container in each drawer</p> 
---	--	--

## Standard Color option :

---



AMERICAN BLUE  
STRUCTURE FINISH



7035 PALE GREY  
STRUCTURE FINISH



DA GREY  
STRUCTURE FINISH



PO RED  
STRUCTURE FINISH

Assembled components are transfer to pre-treatment plant for treating in 7 tank for degrees, zinc, phosphating and passivation.

Material received from pre-treatment department are immediately powder coated in the dust free painting booth and then the articles are put inside a baking oven at a temperature of 180° C for about 20 minutes.



**rk steel smith**  
defining workspace



Plot- B/32 (Part-2) Bileshwar Indl. Estate,  
Opp. G.V.M.M.,  
Odhav-Kathwada Road,  
Ahmedabad - 382415  
Gujarat (INDIA).



+91 94 281 35 100  
+91 98 253 00 059



rksteelsmith@gmail.com  
info@rksteelsmith.com  
sales@rksteelsmith.com



www.rksteelsmith.com