



**rk steel smith**  
defining workspace

# Push-Pull Open Shelving Compactors

PRODUCT RANGE

A clever system.....  
Simple to install and move.....

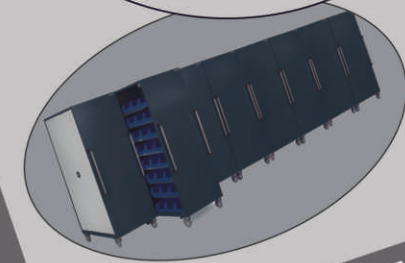
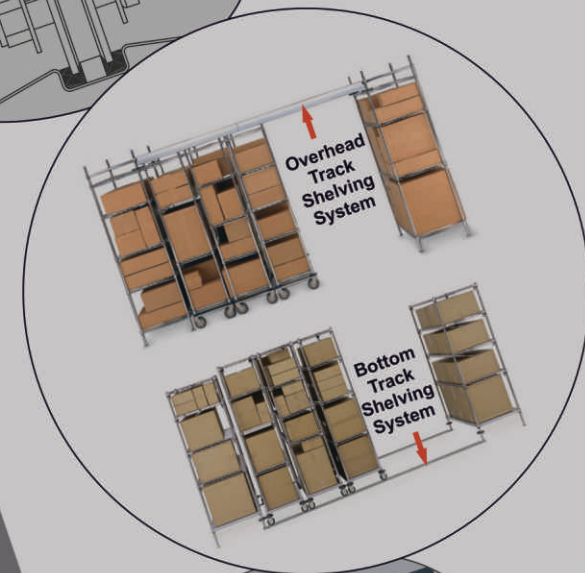
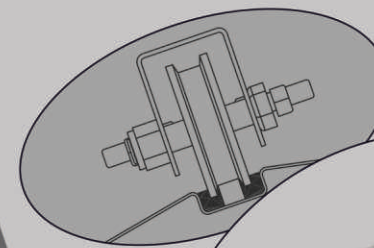

# 2018

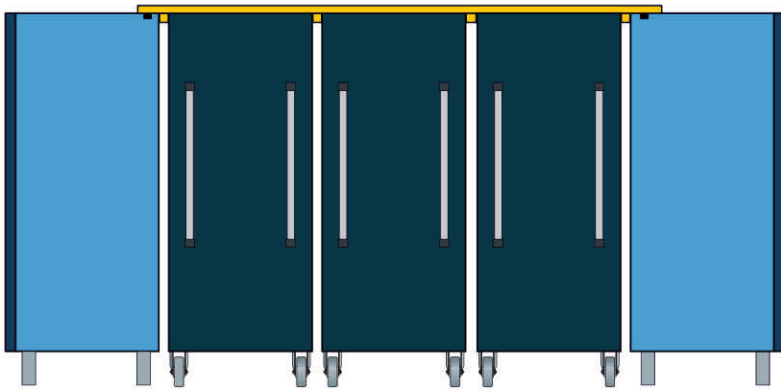

**Overhead Track concept** 4 to 13

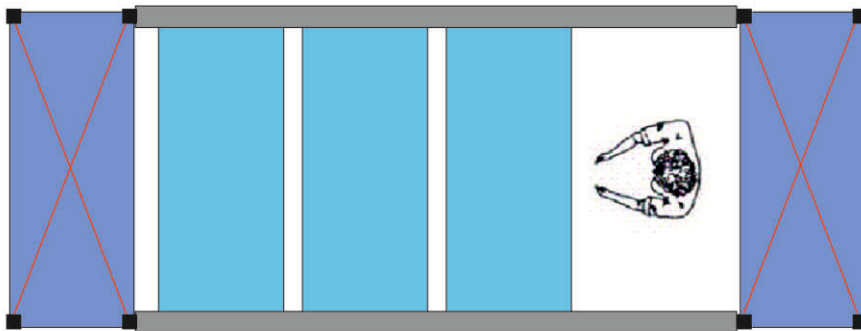

**Overhead Track concept** 14 to 16

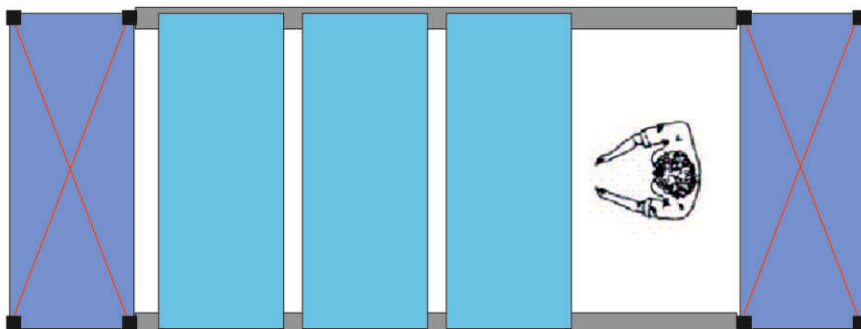

**Bottom Track concept** 17 to 19

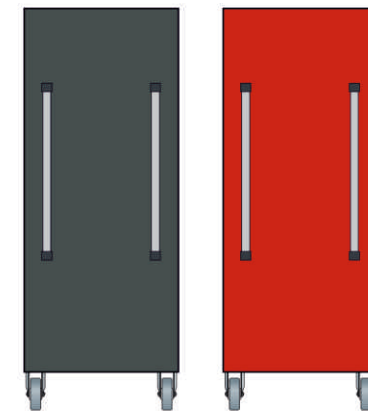
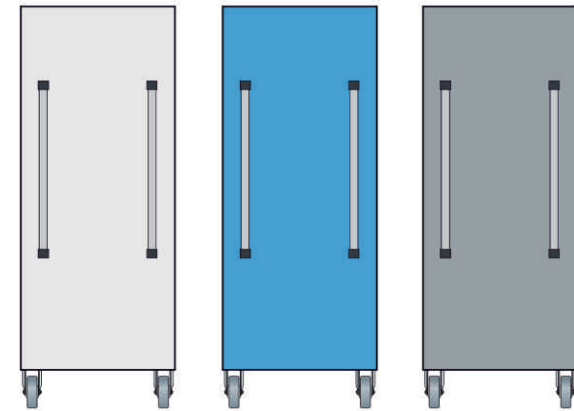

**Colour Option** 20

High Density Storage is a perfect storage solution for:

- **Medical and Dental**  
Patient Charts  
Medical Supplies  
Office Supplies
- **Hospital**  
Patient Charts  
Pharmacy  
Surgical Supplies  
Medical Supplies  
Administrative Files  
Office Supplies
- **Law**  
Client Files  
Library  
Office Supplies
- **Financial**  
Client Files  
Office Supplies
- **Government**  
Federal, State, Local  
Personnel Files  
Administrative Files  
Office Supplies  
Law Enforcement
- **General Office**  
Files  
Office Supplies  
Catalogs, etc.
- **Automotive**  
Service Dep't Parts  
Customer Files  
Office Supplies  
Sales Literature
- **Museum**  
Works on Paper  
Ethnology  
Science  
Textiles  
Administration
- **Retail Stockroom**  
Shoes  
Folded Garments  
Hanging Garments  
Leather Goods  
Accessories  
Electronics  
Home Products  
Furniture  
Optical  
Cosmetics  
Nutrition center  
Other Inventory  
Files  
Office Supplies
- **Fast Food**  
Paper Goods  
Non-Perishables  
Refrigerated Storage
- **Restaurant**  
Service Items  
Linens  
Cookware  
Non-perishables  
Refrigerated Storage
- **Supermarket**  
Non-perishable Food  
Refrigerated Storage  
Household Items  
Pharmacy

BOOST  
STORAGE SPACE  
BY UP TO  
**50%**  
WITH NO ADDED  
CONSTRUCTION  
COSTS.

**Overhead  
Track**

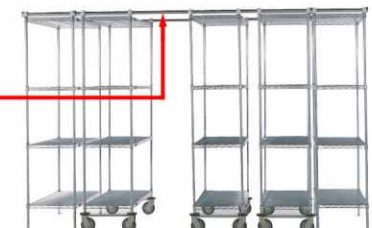

**Bottom  
Track**

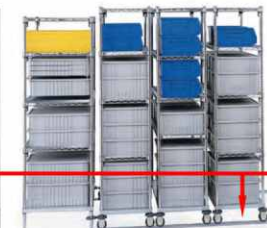
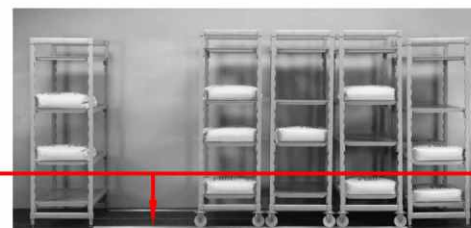



## The bearing system for all operating purposes

**Housing 16 Gauge (1.5mm thk.)  
&  
Shelve 14 Gauge (2.0mm thk.)  
Construction**

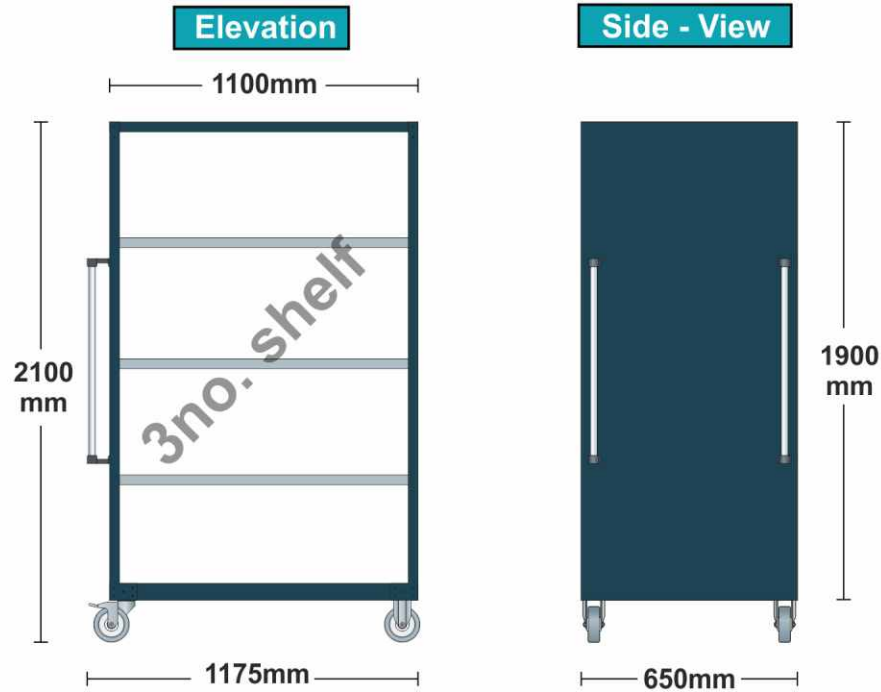

- A** Stationary Fix Cabinet
  - B** Mobile Cabinet
- Cabinet width - 1100mm**  
**Cabinet depth - 650mm (Standard)**  
**Shelf - 3no.**  
**Cabinet height - 1900mm**  
**Each Cabinet load cap. - 400kg.**  
**Overall height - 2100mm (Includes castor and overhead track)**

- 400**  
 Max. load capacity 400kg. each drawer
- 2**  
 125 dia. wheel 2-brake
- 2**  
 125 dia. wheel 2-fix
- Both - sided access**

**Close Shelving (4 to 7 Cabinet Concept) on page no. - 05**

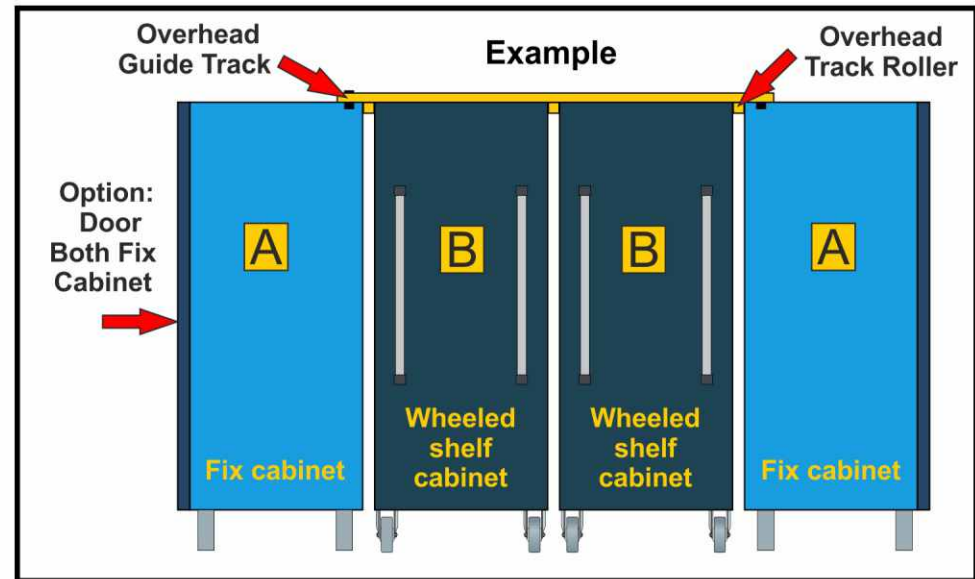

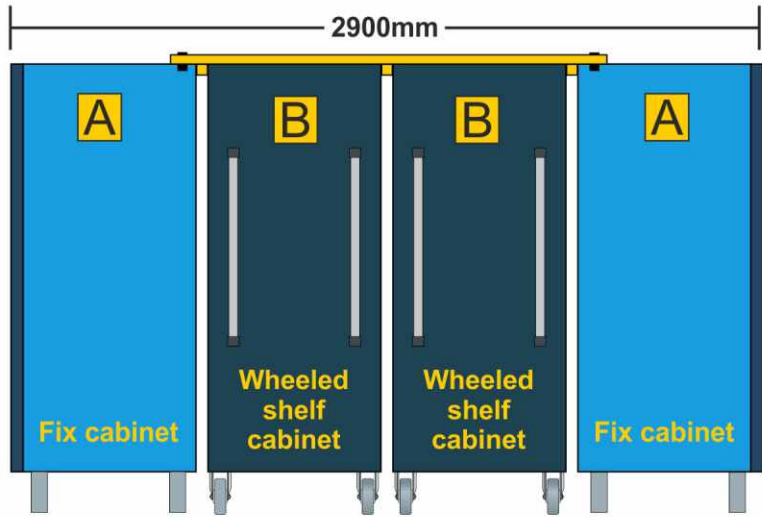

4 Cabinets

Order no. **RK COMPT PU/PL** 01

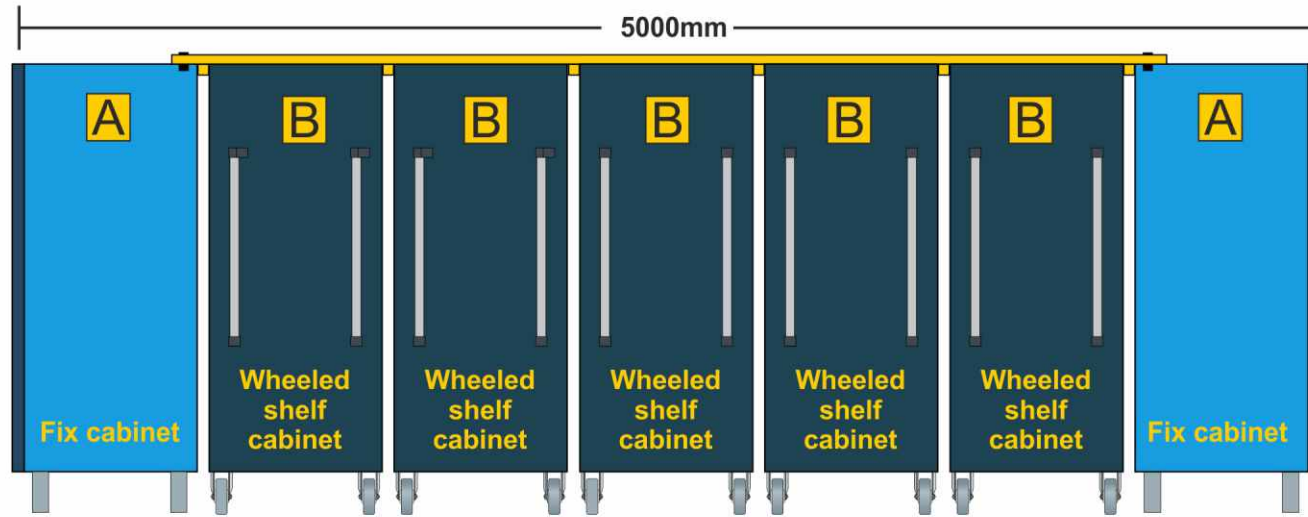

7 Cabinets

Order no. **RK COMPT PU/PL** 02

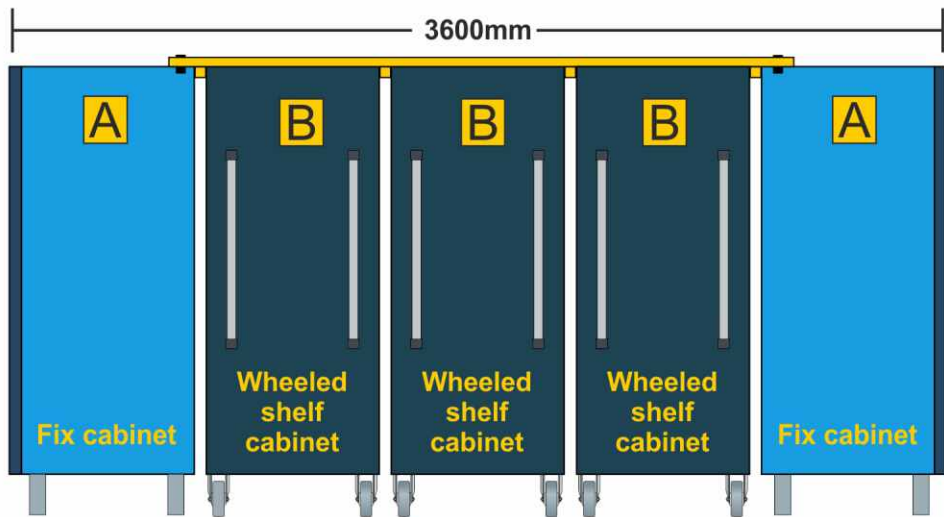

5 Cabinets

Order no. **RK COMPT PU/PL** 03

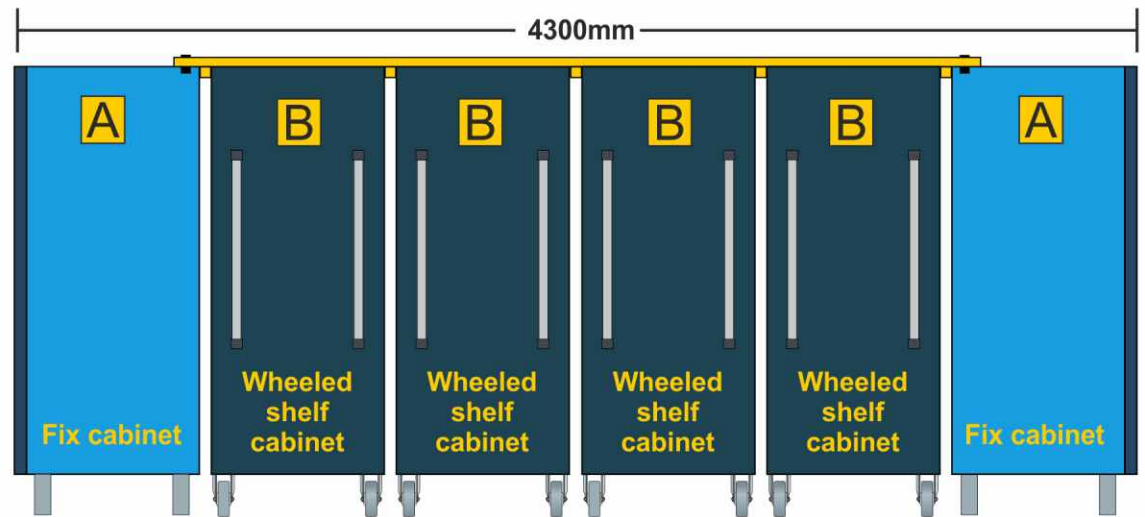

6 Cabinets

Order no. **RK COMPT PU/PL** 04

## The bearing system for all operating purposes

**Housing 16 Gauge (1.5mm thk.)  
&  
Shelve 14 Gauge (2.0mm thk.)  
Construction**

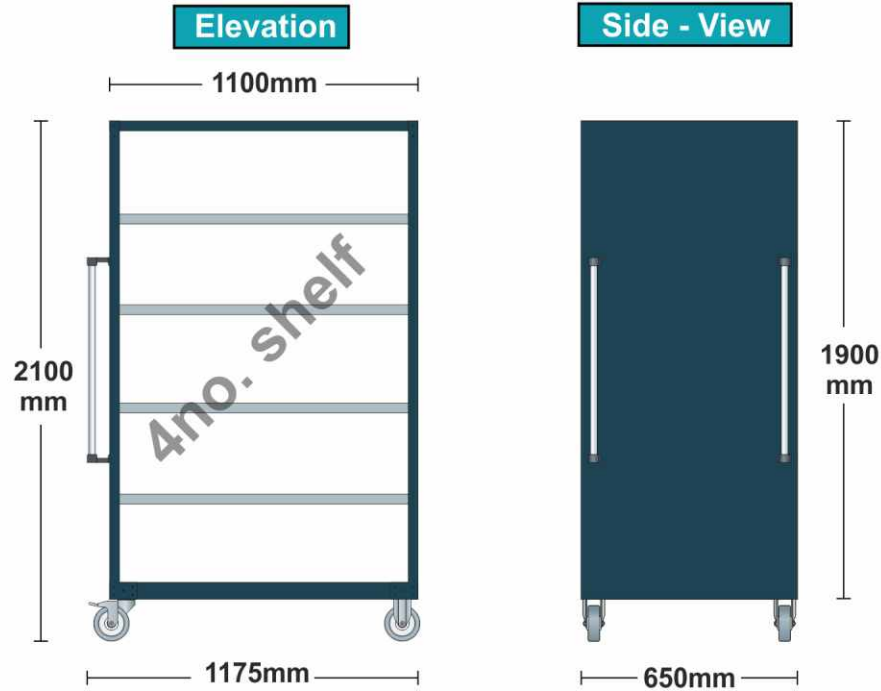

- A** Stationary Fix Cabinet
  - B** Mobile Cabinet
- Cabinet width - 1100mm**  
**Cabinet depth - 650mm (Standard)**  
**Shelf - 4no.**  
**Cabinet height - 1900mm**  
**Each Cabinet load cap. - 400kg.**  
**Overall height - 2100mm (Includes castor and overhead track)**

- Max. load capacity 400kg. each drawer
- 125 dia. wheel 2-brake
- 125 dia. wheel 2-fix
- Both - sided access

**Close Shelving (4 to 7 Cabinet Concept) on page no. - 07**

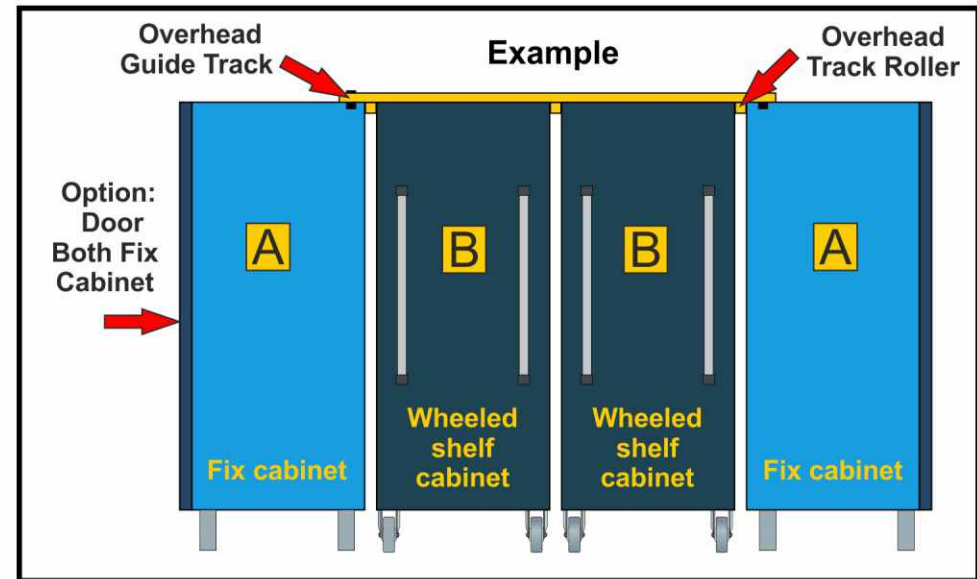

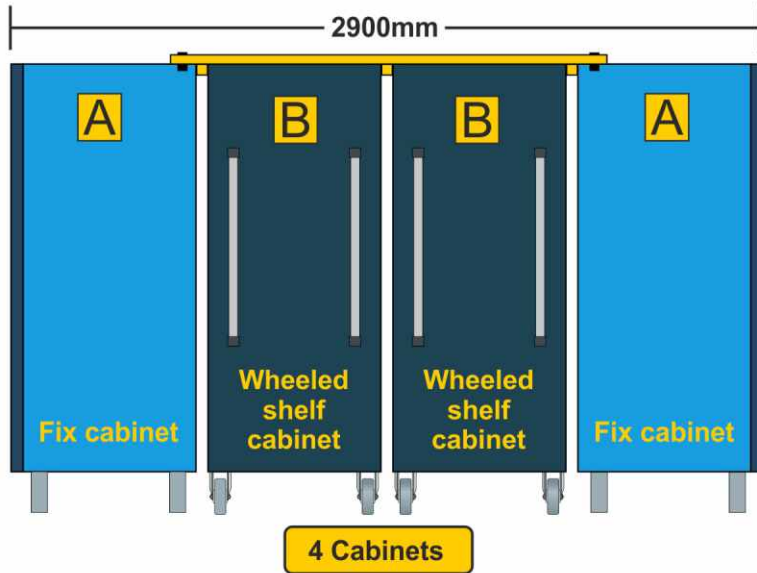

Order no. **RK COMPT PU/PL** 05

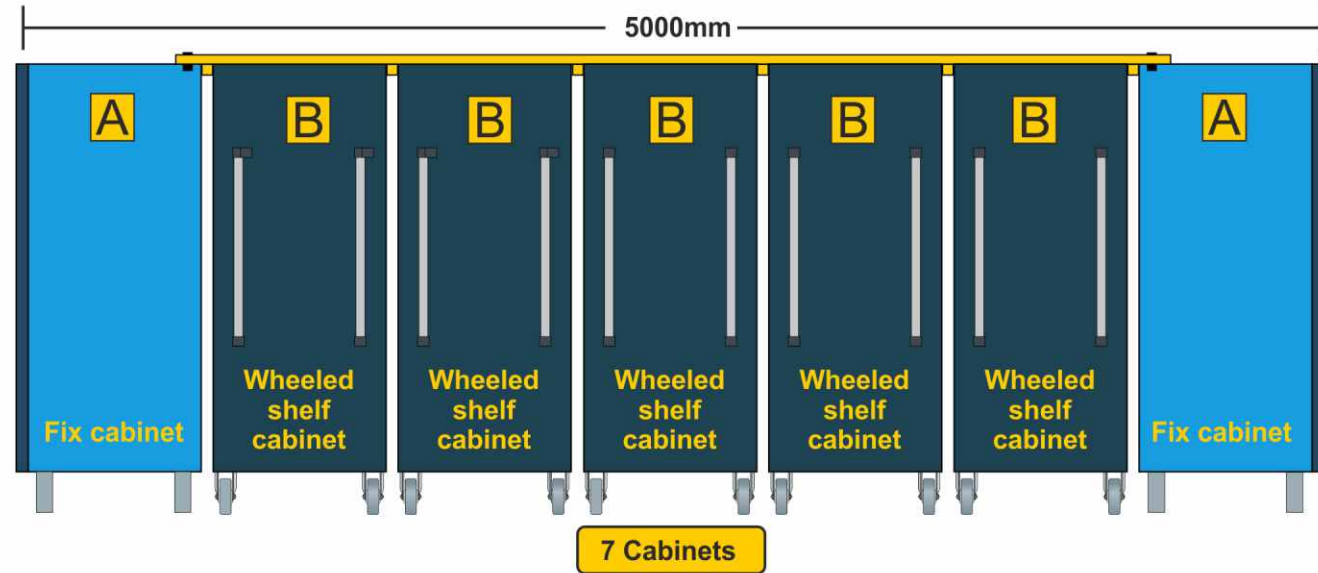

Order no. **RK COMPT PU/PL** 06

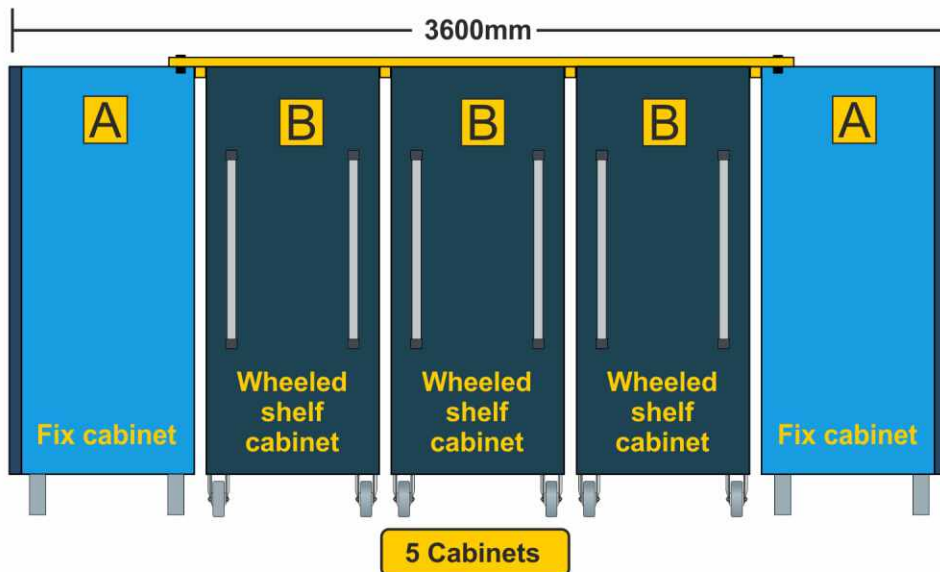

Order no. **RK COMPT PU/PL** 07

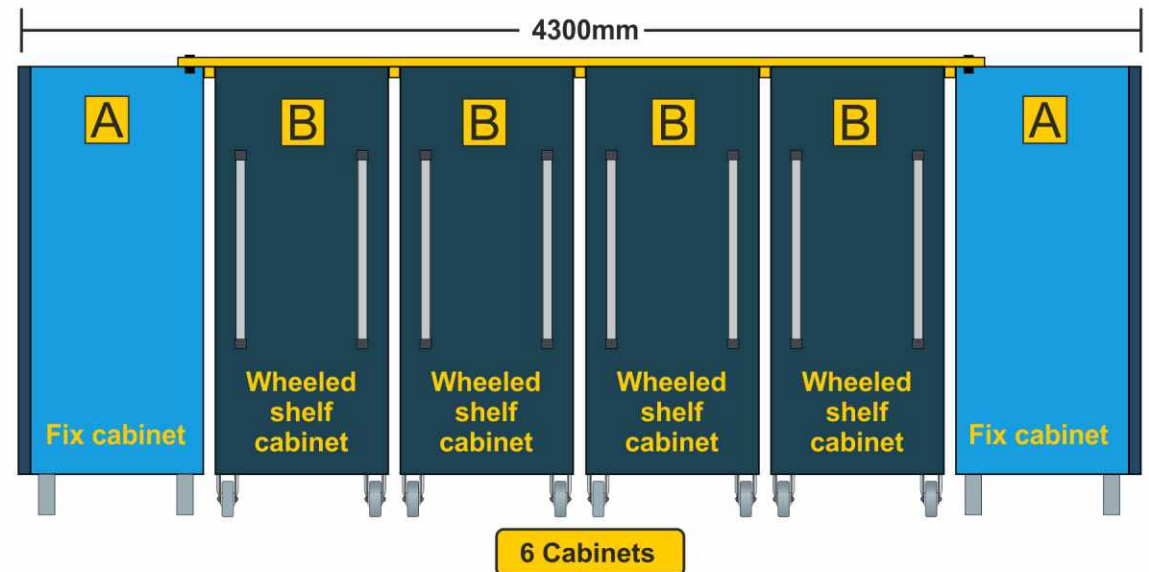

Order no. **RK COMPT PU/PL** 08



## The bearing system for all operating purposes

**Housing 16 Gauge (1.5mm thk.)  
&  
Shelve 14 Gauge (2.0mm thk.)  
Construction**

**Elevation**

**Side - View**

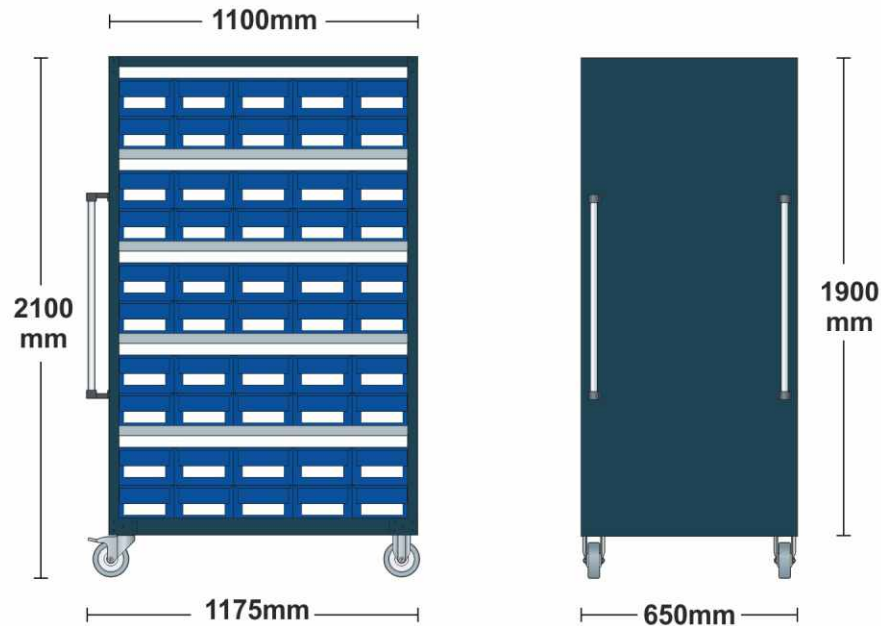

- A** Stationary Fix Cabinet
- B** Mobile Cabinet

**Cabinet width - 1100mm**  
**Cabinet depth - 650mm (Standard)**  
**Shelf - 4no.**  
**Cabinet height - 1900mm**  
**Each Cabinet load cap. - 400kg.**  
**Overall height - 2100mm (Includes castor and overhead track)**

**Plastic bin size:  
Bull -35: 208 W. X 300 D. X 158 H.**

-   
**400**  
 Max. load capacity 400kg. each drawer
-   
**2**  
 125 dia. wheel 2-brake
-   
**2**  
 125 dia. wheel 2-fix
-   
 Including 100 Storage bins each Cabinet
-   
 Both - sided access

**Close Shelving (4 to 7 Cabinet Concept) on page no. - 09**

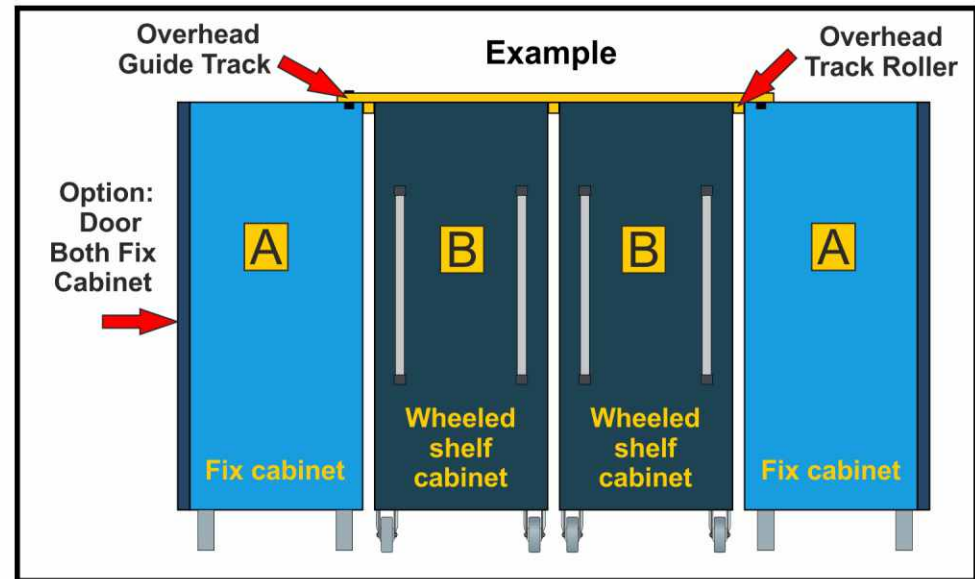



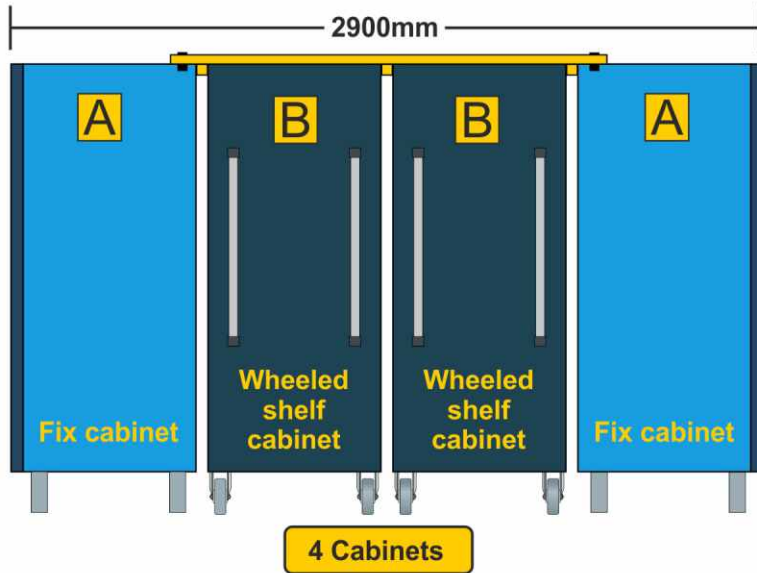

Order no. **RK COMPT PU/PL** 09

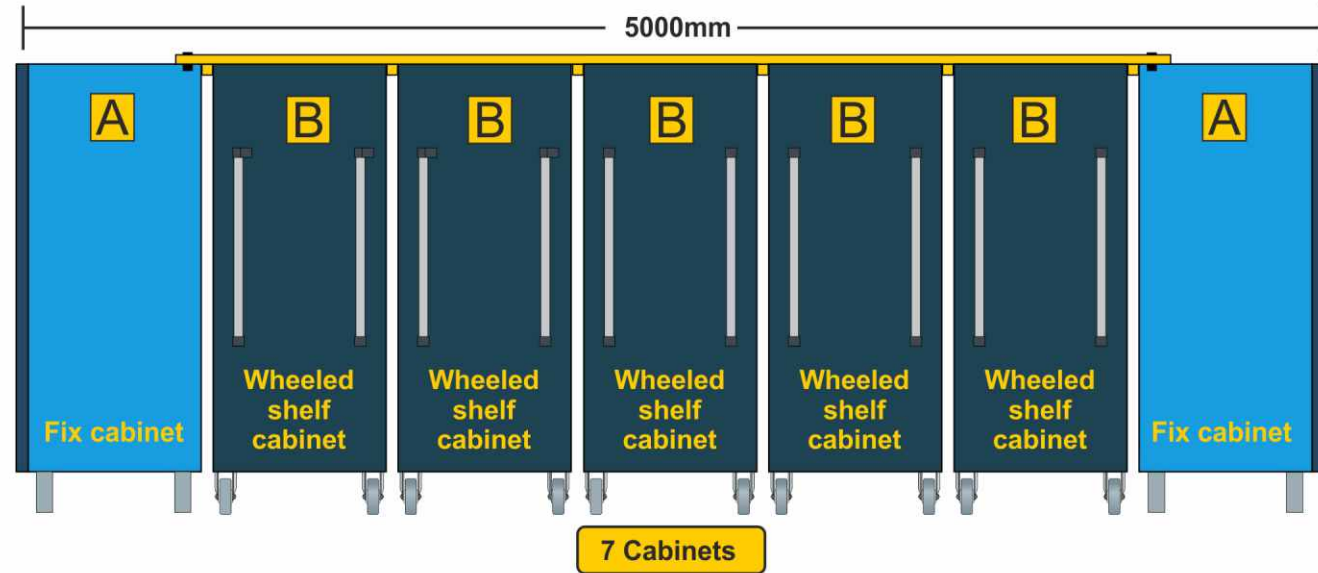

Order no. **RK COMPT PU/PL** 10

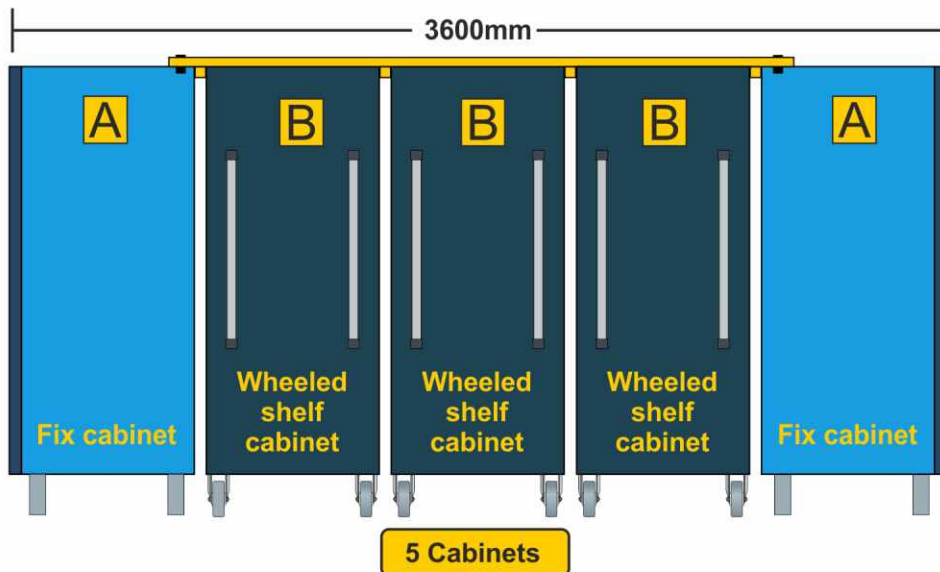

Order no. **RK COMPT PU/PL** 11

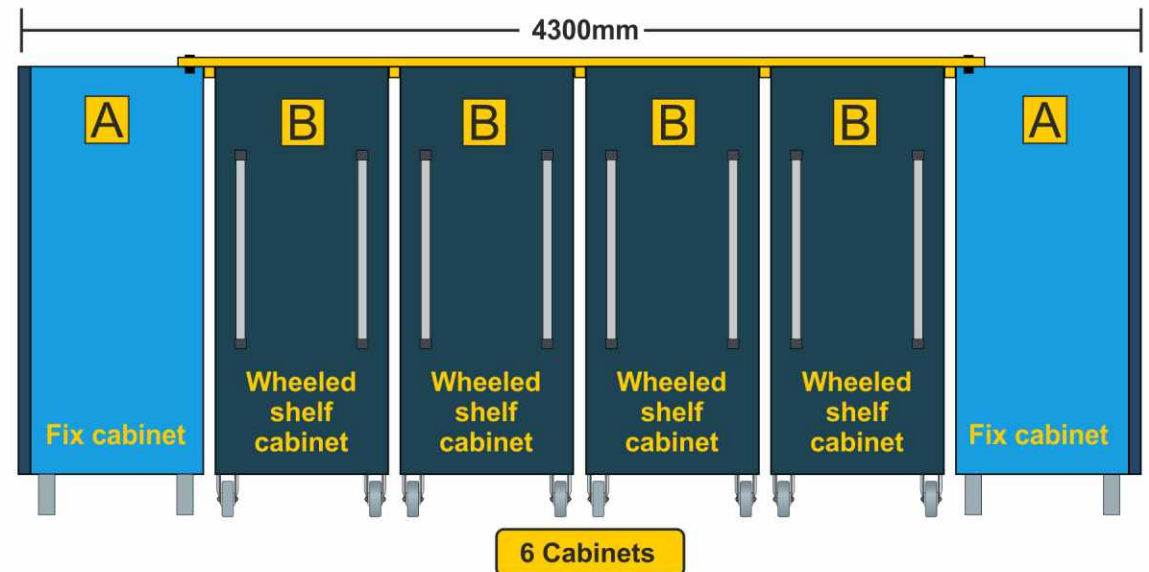

Order no. **RK COMPT PU/PL** 12

## The bearing system for all operating purposes

**Housing 16 Gauge (1.5mm thk.)  
&  
Shelve 14 Gauge (2.0mm thk.)  
Construction**

**Elevation**

**Side - View**

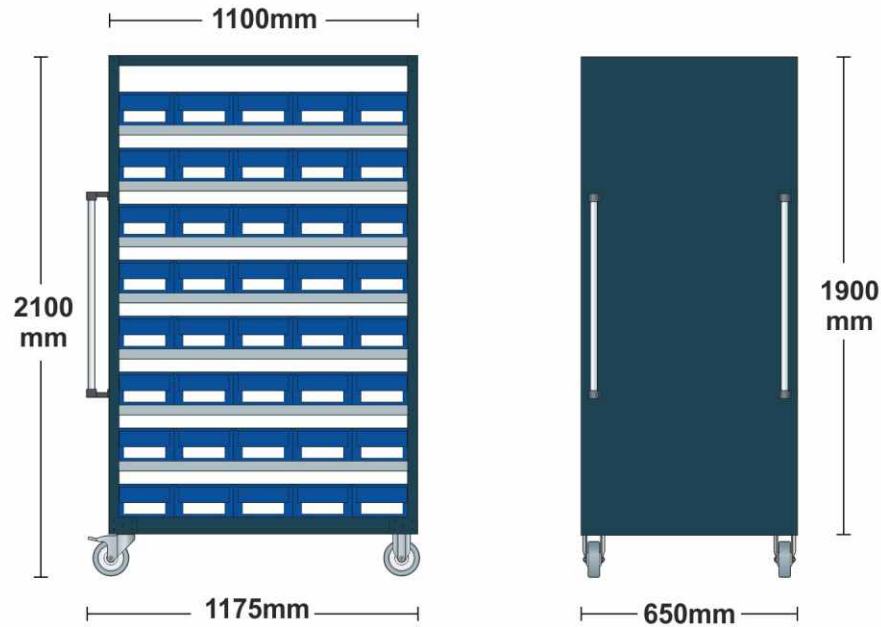

- A** Stationary Fix Cabinet
  - B** Mobile Cabinet
- Cabinet width - 1100mm**  
**Cabinet depth - 650mm (Standard)**  
**Shelf - 7no.**  
**Cabinet height - 1900mm**  
**Each Cabinet load cap. - 400kg.**  
**Overall height - 2100mm (Includes castor and overhead track)**
- Plastic bin size:  
Bull -35: 208 W. X 300 D. X 158 H.**

-  **Max. load capacity 400kg. each drawer**
-  **125 dia. wheel 2-brake**
-  **125 dia. wheel 2-fix**
-  **Including 80 Storage bins each Cabinet**
-  **Both - sided access**

**Close Shelving (4 to 7 Cabinet Concept) on page no. - 11**

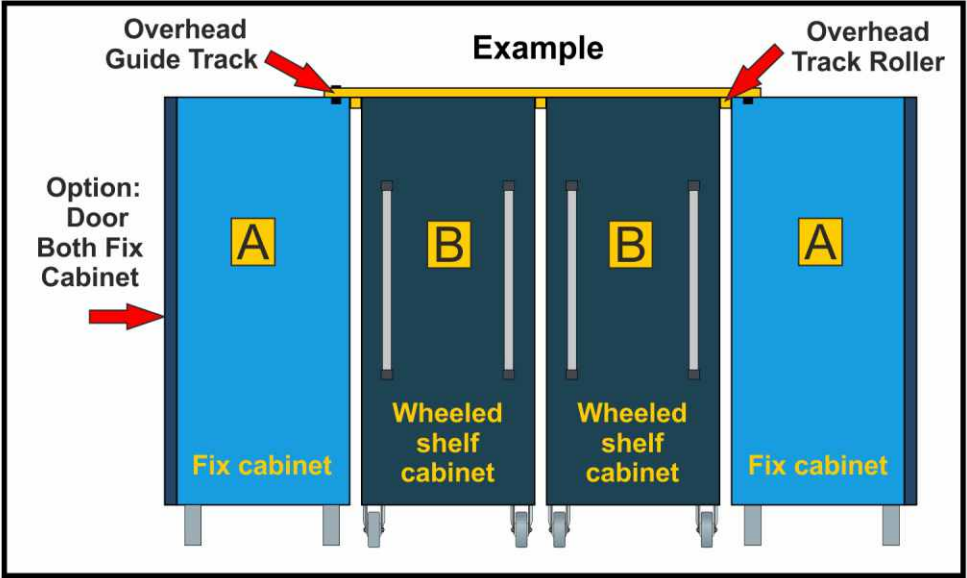

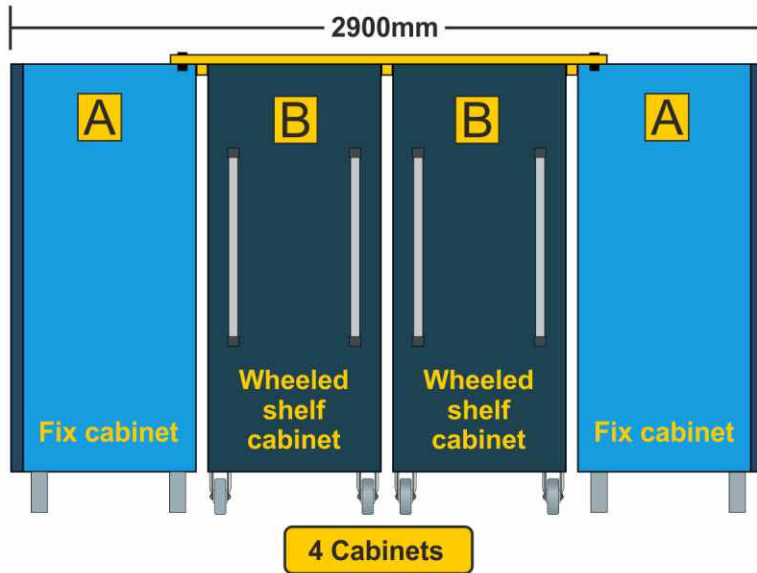

Order no. **RK COMPT PU/PL** 13

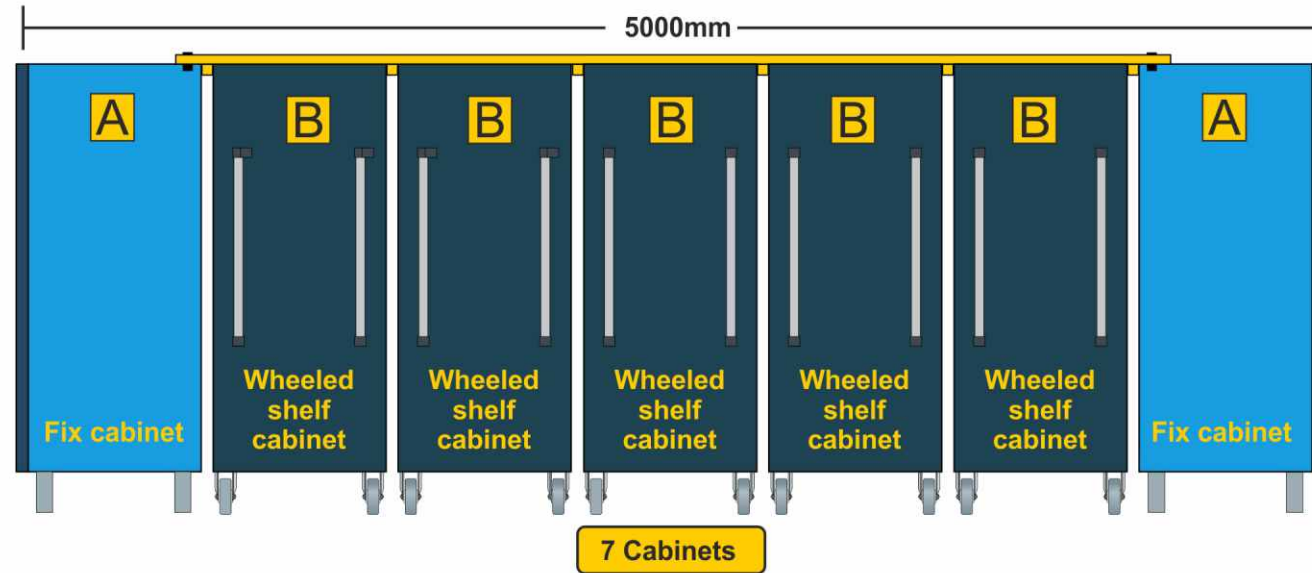

Order no. **RK COMPT PU/PL** 14

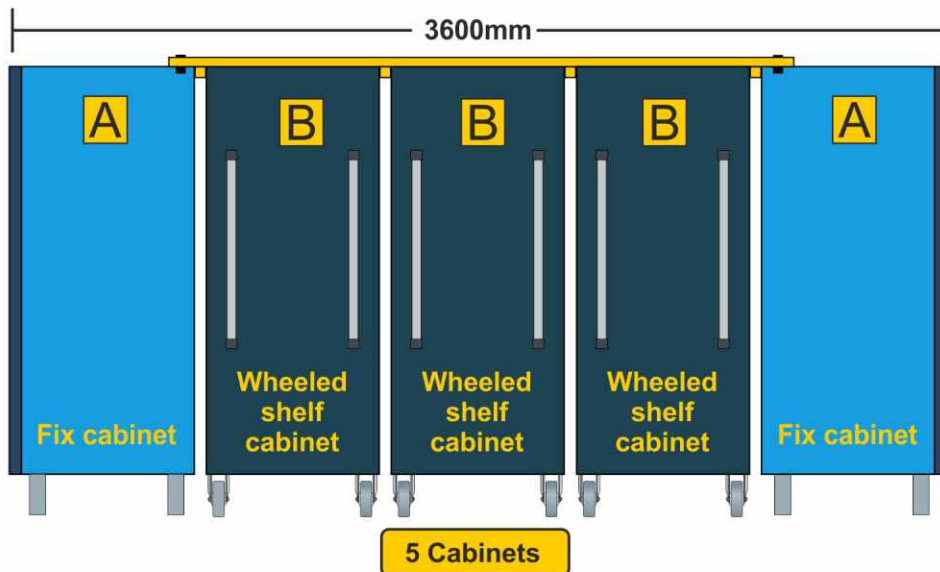

Order no. **RK COMPT PU/PL** 15

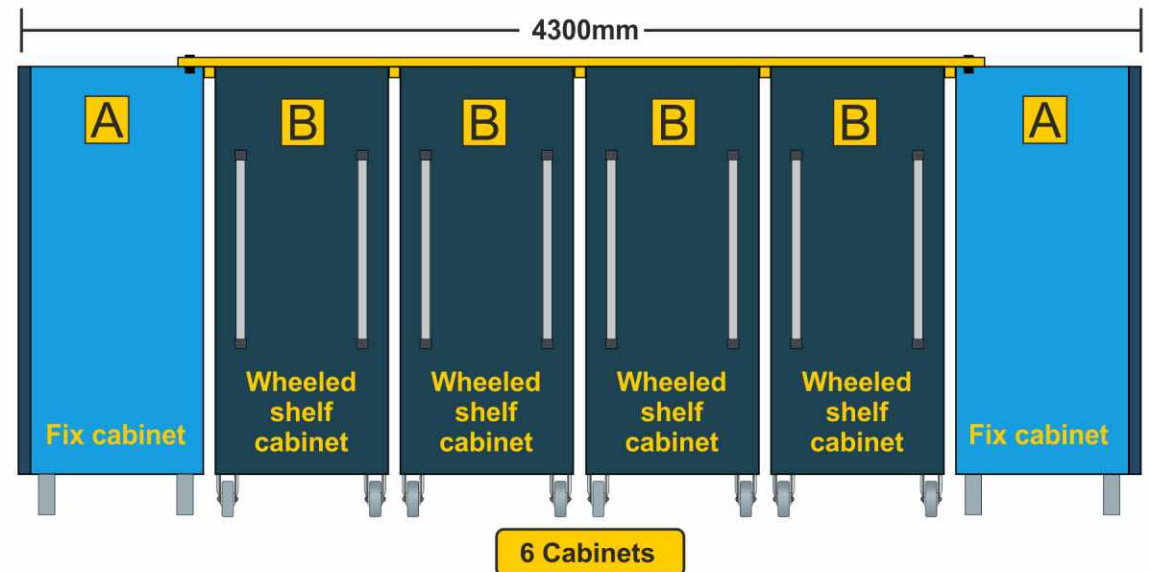

Order no. **RK COMPT PU/PL** 16



## The bearing system for all operating purposes

**Housing 16 Gauge (1.5mm thk.)  
&  
Shelve 14 Gauge (2.0mm thk.)  
Construction**

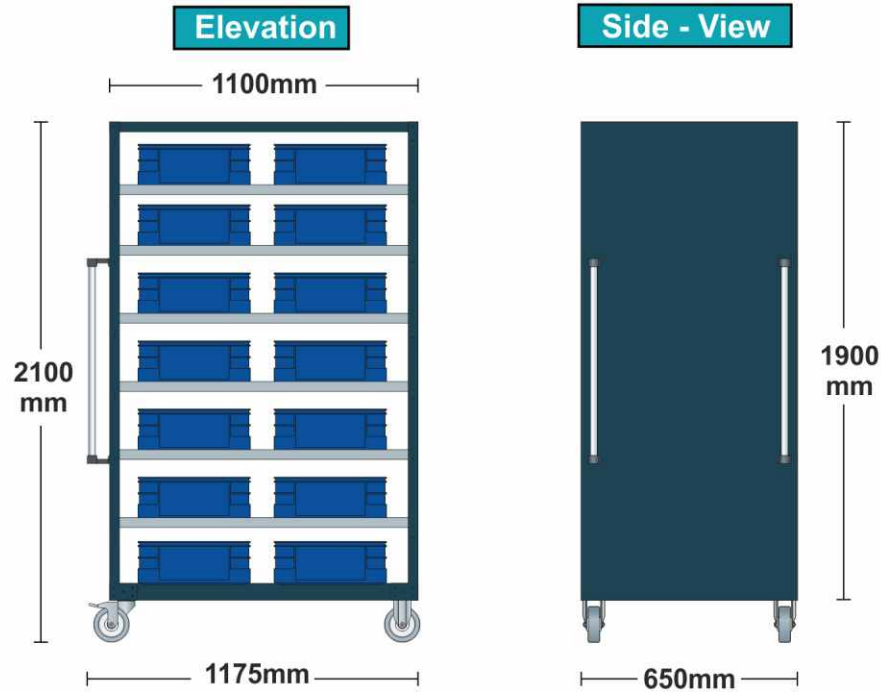

-   
**400**  
 Max. load capacity 400kg. each drawer
-   
**2**  
 125 dia. wheel 2-brake
-   
**2**  
 125 dia. wheel 2-fix
-   
 Including 14 Storage crates each Cabinet
-   
 Both - sided access

**Close Shelving (4 to 7 Cabinet Concept) on page no. - 13**

- A** Stationary Fix Cabinet
- B** Mobile Cabinet

**Cabinet width - 1100mm**

**Cabinet depth - 650mm (Standard)**

**Shelf - 7no.**

**Cabinet height - 1900mm**

**Each Cabinet load cap. - 400kg.**

**Overall height - 2100mm (Includes castor and overhead track)**

**Plastic crates size:  
600 W. X 400 D. X 150/175 H.**

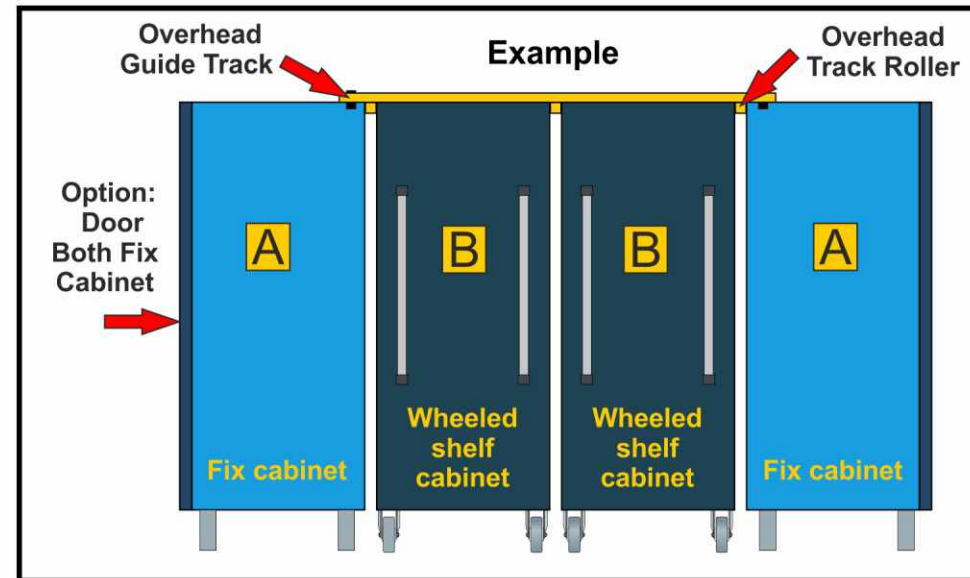

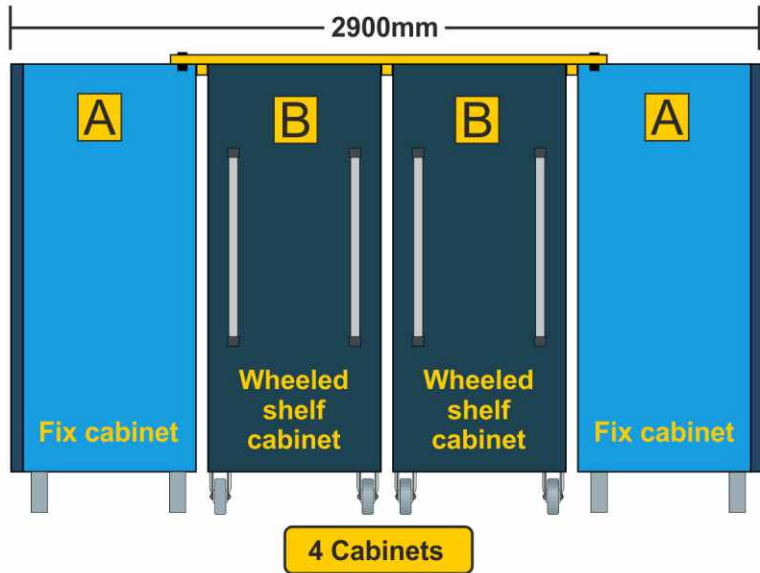

Order no. **RK COMPT PU/PL** 17

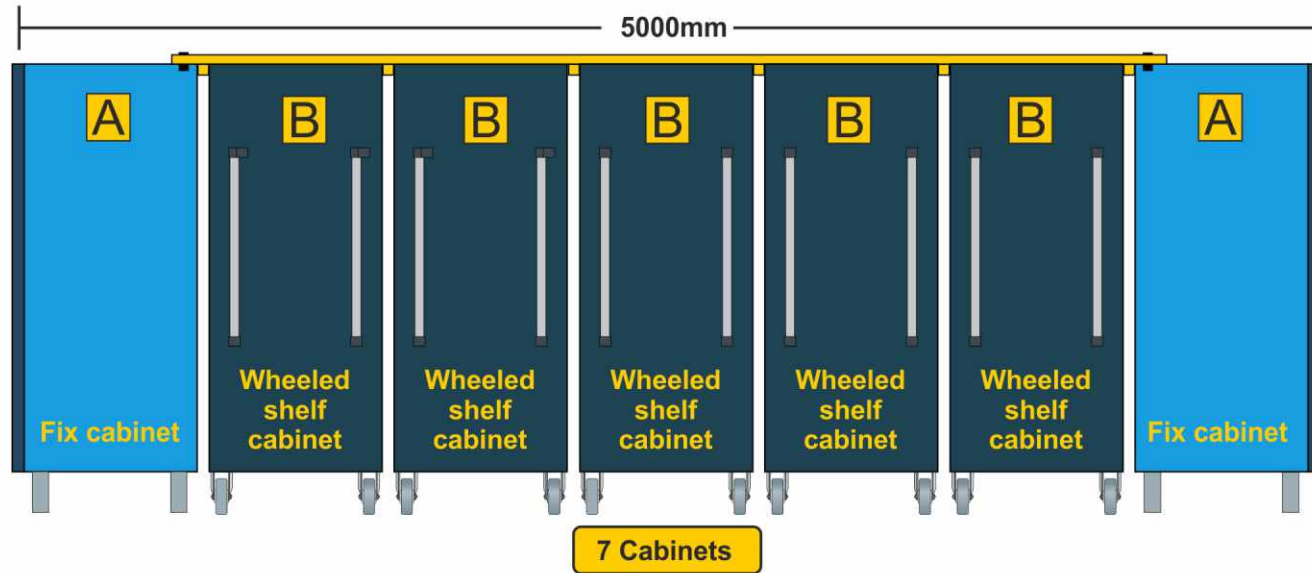

Order no. **RK COMPT PU/PL** 18

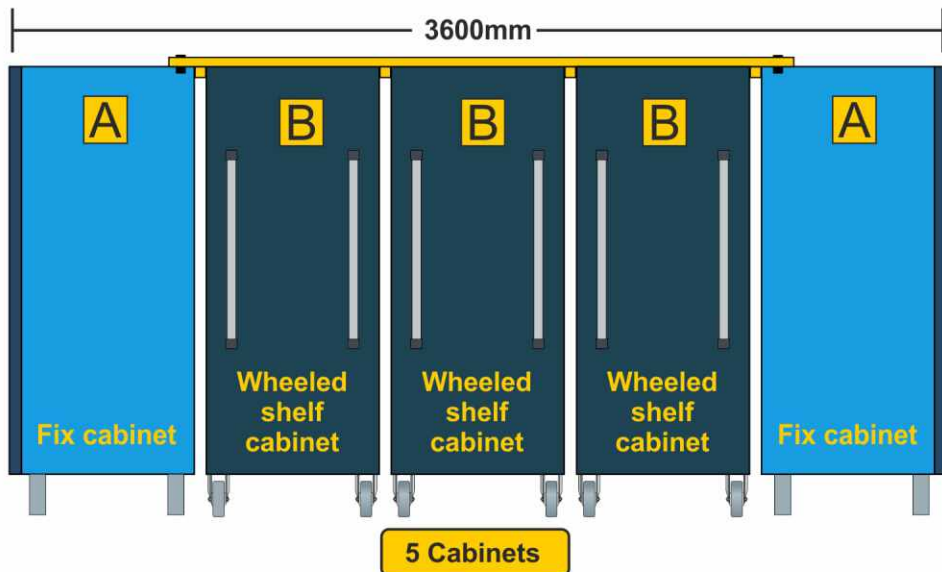

Order no. **RK COMPT PU/PL** 19

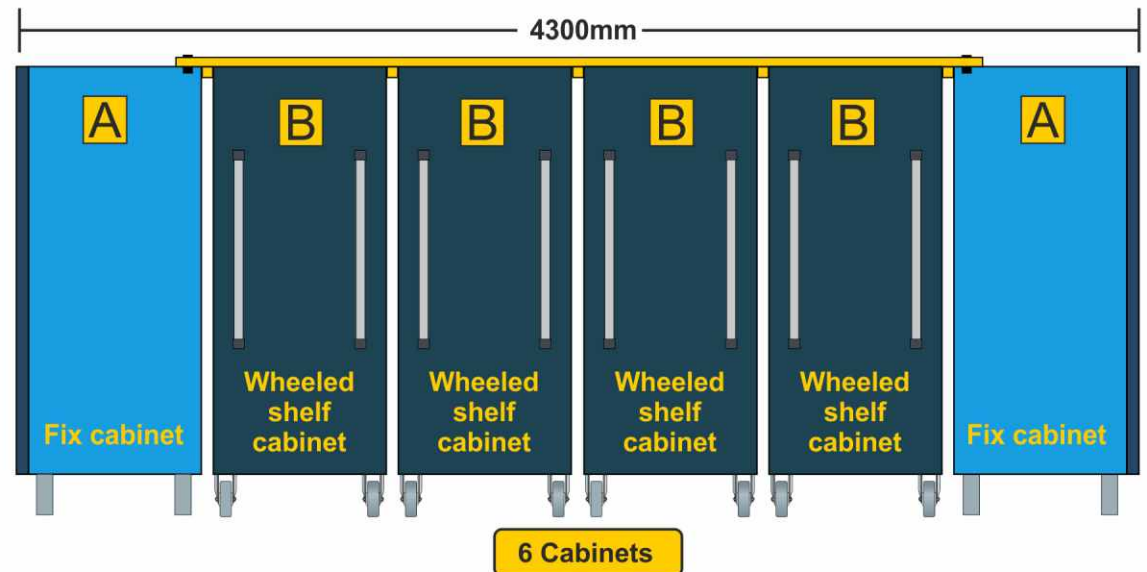

Order no. **RK COMPT PU/PL** 20



**Only for narrow rooms / corridors & wall touch.**

**Economical  
New Concept**

Top-Track Overhead Track System:

- Active Aisle: Mobile shelving units positioned on an overhead track between two stationary units can easily be repositioned for access to the stored contents on the shelves.
- Overhead aluminum tracks, top-mounted rollers and rigid casters guide the mobile shelving units in a straight line.
- Clean design: The overhead track assures aisles are completely clear for easy cleaning and for access by carts and trollies.
- The overhead track compensates for uneven floor surfaces .
- Strong: Mobile aisle units address medium duty applications. Each mobile aisle unit has a maximum unit capacity of 500kg. evenly distributed.
- Versatile: Standard single deep Top-Track is compatible with open shelving and close shelving Top-Track has finishes that cover a range of dry and wet/damp environments.
- Double-Deep configurations can be created where two systems are joined together to increase the overall depth of the shelving for greater storage capacity.





Only for narrow rooms / corridors & wall touch.

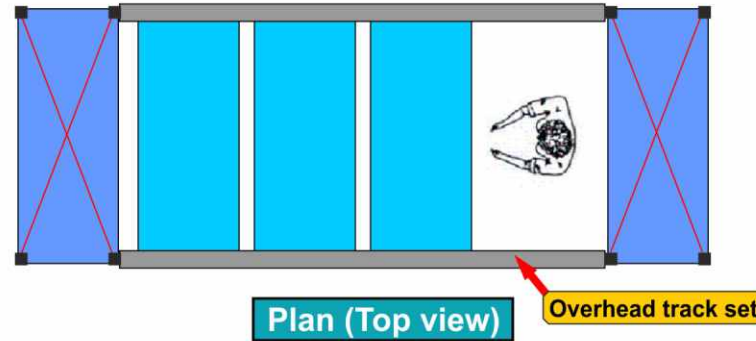
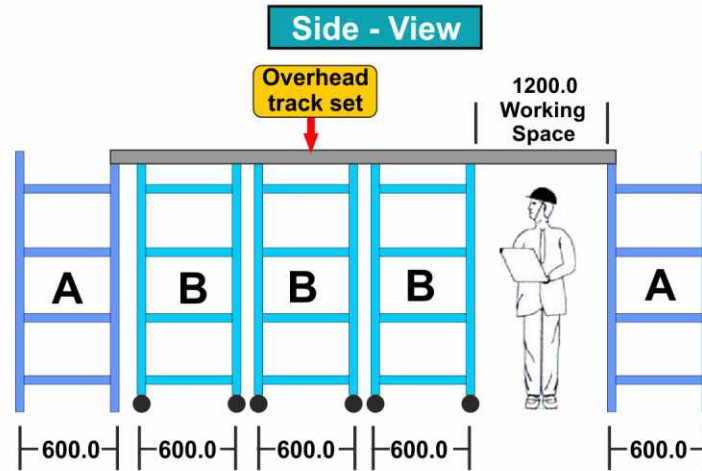
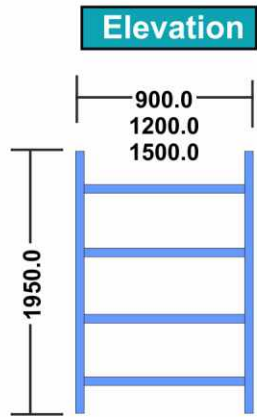

- A** Stationary Fix Frame
  - B** Mobile Frame
- Frame width - 900mm, 1200mm, 1500mm
- Frame depth - **600mm** - \* (Standard)
- Frame depth - **500mm** - \* (Option)
- Shelf - 4no.
- Frame height - 1750mm
- Each shelf load cap. - 150kg.
- Each frame load cap. - 600kg.
- Overall height - 1950mm  
(Includes castor and overhead track)

Frame & Shelf  
14 Gauge (2.0mm thk.)  
Construction

Open Shelving (5 Frame Concept)  
on page no.-16

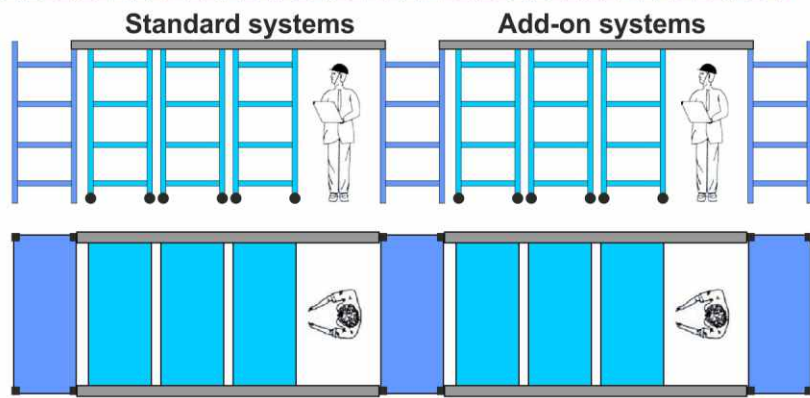

**Economical  
New Concept**

Only for narrow rooms / corridors & wall touch.

Standard systems

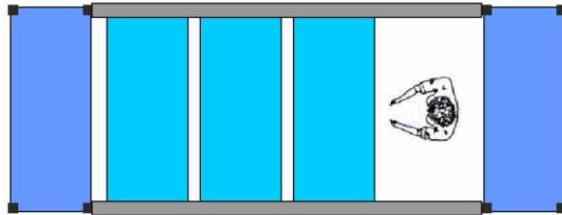

4.0mtr. W X 1.20mtr. D X 2.5mtr. H  
Floor Space

Order no. **RK COMPT PU/PL** 21

Standard systems

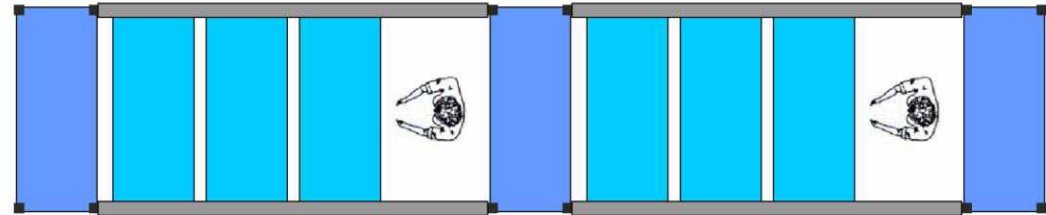

7.5mtr. W X 1.20mtr. D X 2.5mtr. H  
Floor Space

Order no. **RK COMPT PU/PL** 22

Standard systems

Add-on systems

Add-on systems

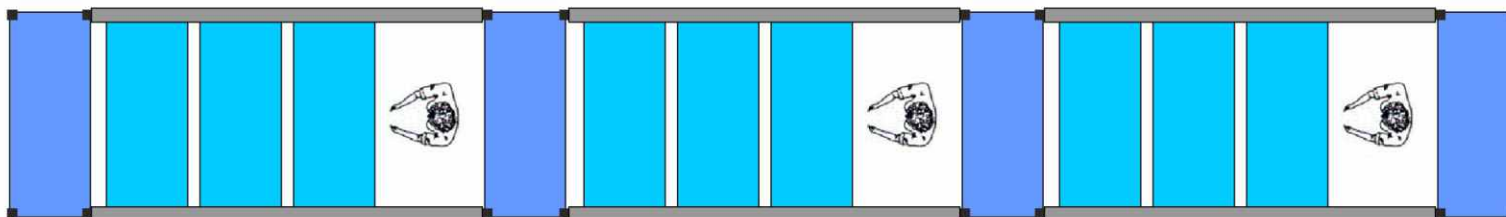

4.0mtr. W X 1.20mtr. D X 2.5mtr. H  
Floor Space

Order no. **RK COMPT PU/PL** 23

**Only for narrow rooms / corridors & wall touch.**



## Bottom floor track system

- Smooth function: Mobile shelving units glide easily along aluminum and stainless steel floor tracks
- Floor tracks compensate for rough or choppy floor surfaces.
- Strong and Ergonomic: Mobile aisle units address medium duty applications. Each mobile aisle unit has a maximum unit capacity of 500kg. evenly distributed.
- Protects floors: Floor tracks protect floors from wear and tear and do not require mounting to the floor.
- Versatile: Standard single deep Top-Track is compatible with open shelving and close shelving Top-Track has finishes that cover a range of dry and wet/damp environments.
- Bottom floor track system has finishes that cover a range of dry and wet/damp environments.
- Double-Deep configurations can be created where two systems are joined together to increase the overall depth of the storage system for greater storage capacity.

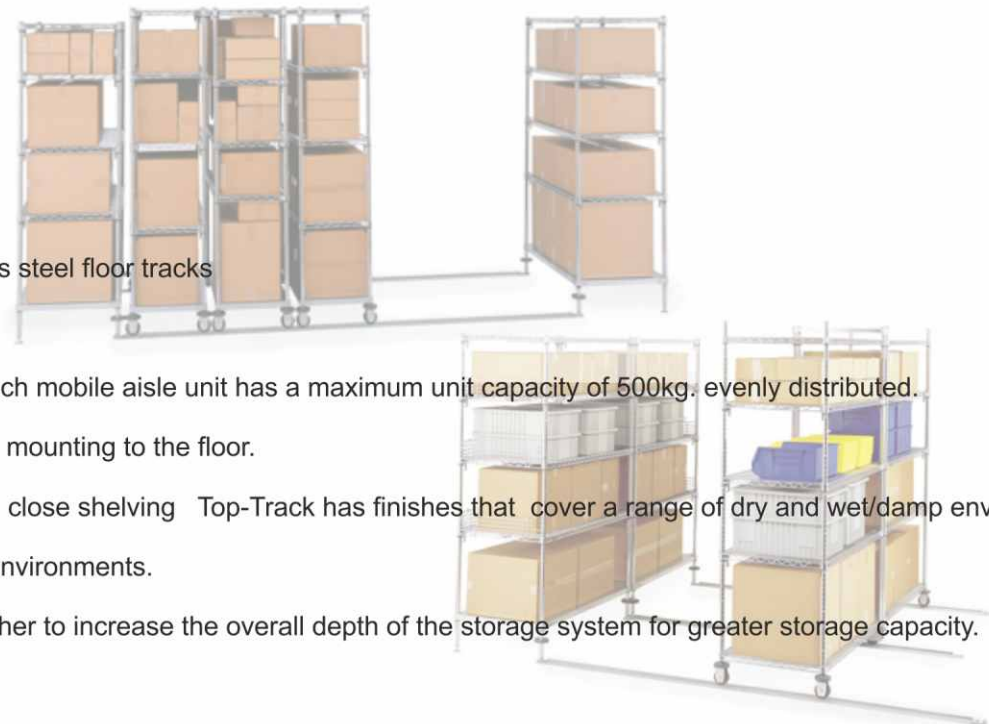

**Bottom track set**

**System Components**  
 A = Stationary End Units  
 B = Mobile Units  
 C = Floor Track  
 D = Stationary Intermediate Unit  
 E = Active Aisle

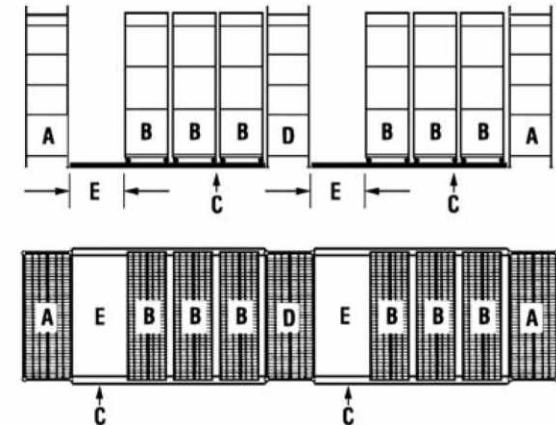



Only for narrow rooms / corridors & wall touch.

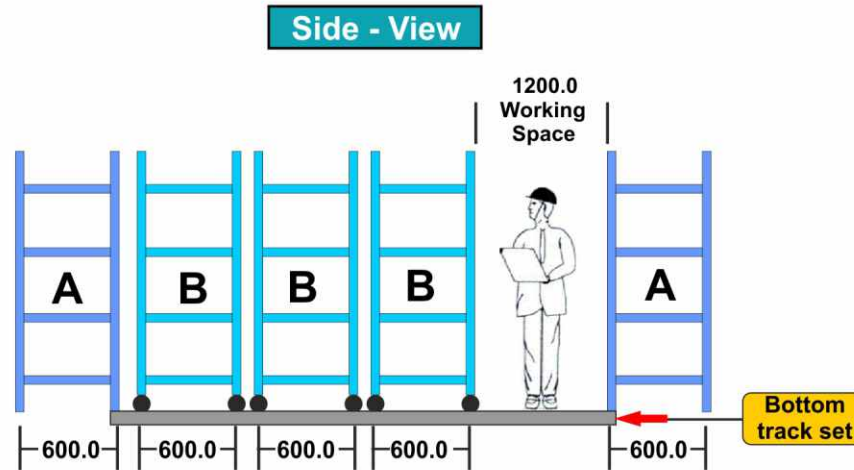
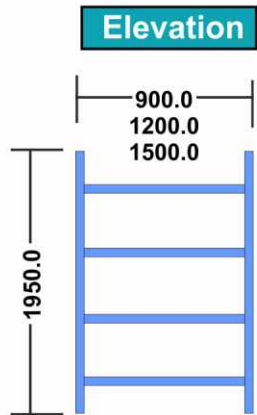

- A** Stationary Fix Frame
  - B** Mobile Frame
- Frame width - 900mm, 1200mm, 1500mm
- Frame depth - **600mm** \* (Standard)
- Frame depth - **500mm** \* (Option)
- Shelf - 4no.
- Frame height - 1750mm
- Each shelf load cap. - 150kg.
- Each frame load cap. - 600kg.
- Overall height - 1950mm  
(Includes castor and overhead track)

Frame & Shelf  
14 Gauge (2.0mm thk.)  
Construction

Open Shelving (5 Frame Concept)  
on page no.-19

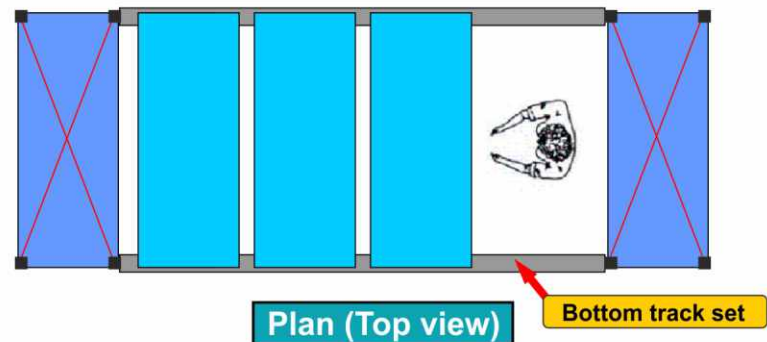

**Economical  
New Concept**

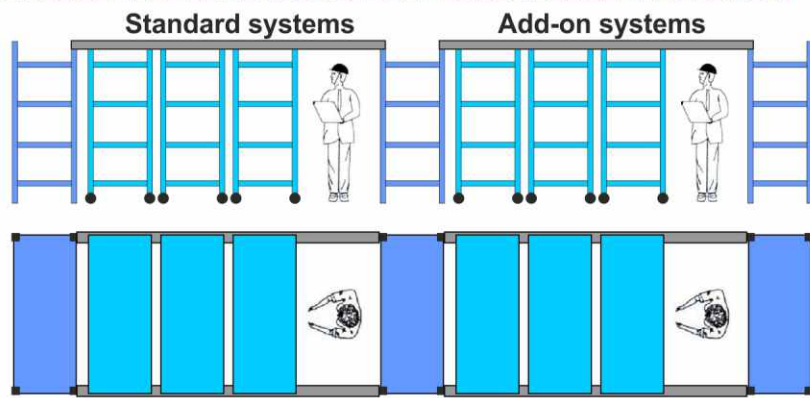

Only for narrow rooms / corridors & wall touch.

Standard systems

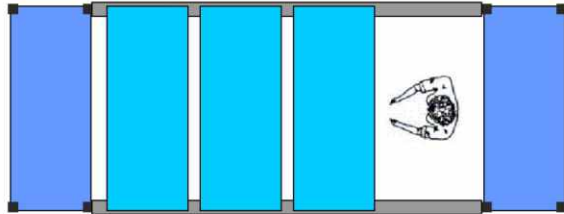

4.0mtr. W X 1.20mtr. D X 2.5mtr. H  
Floor Space

Order no. **RK COMPT PU/PL** 24

Standard systems

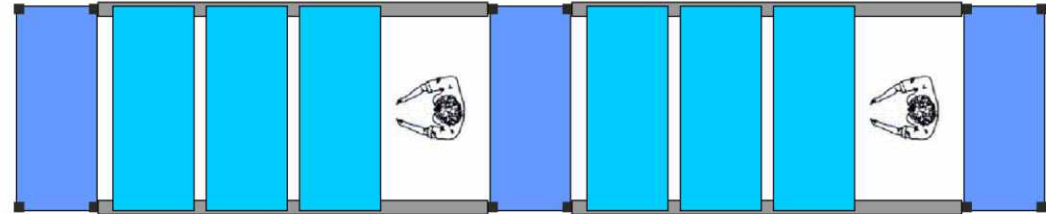

7.5mtr. W X 1.20mtr. D X 2.5mtr. H  
Floor Space

Order no. **RK COMPT PU/PL** 25

Standard systems

Add-on systems

Add-on systems

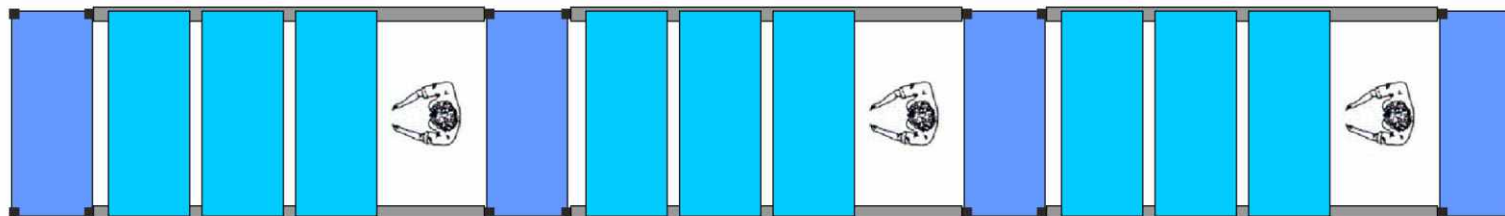

11.0mtr. W X 1.20mtr. D X 2.5mtr. H  
Floor Space

Order no. **RK COMPT PU/PL** 26

## Standard Color option :

---

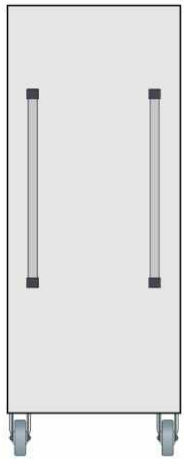

7035 Pale Grey - Str.

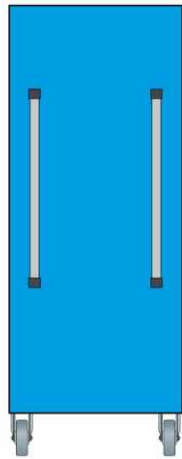

5015 American Blue - Str.

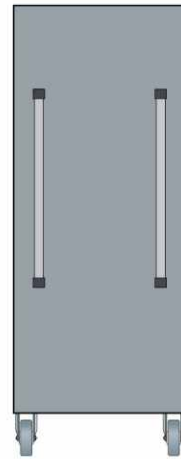

7001 Munsell Grey - Str.

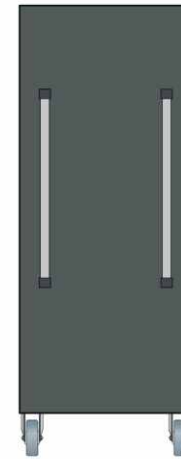

7031 D. A. Grey - Str.

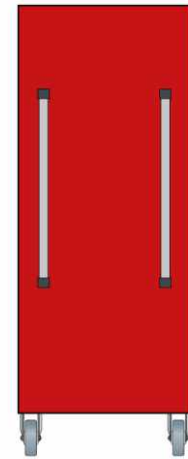

3001 Red - Str.

Assembled components are transfer to pre-treatment plant for treating in 7 tank for degrees, zinc, phosphating and passivation.

Material received from pre-treatment department are immediately powder coated in the dust free painting booth and then the articles are put inside a baking oven at a temperature of 180° C for about 20 minutes.





**rk steel smith**  
defining workspace



Plot- B/32 (Part-2) Bileshwar Indl. Estate,  
Opp. G.V.M.M.,  
Odhav-Kathwada Road,  
Ahmedabad - 382415  
Gujarat (INDIA).



+91 94 281 35 100  
+91 98 253 00 059



rksteelsmith@gmail.com  
info@rksteelsmith.com  
sales@rksteelsmith.com



www.rksteelsmith.com