



**rk steel smith**  
defining workspace

# Industrial Vertical Drawer CNC Tool Cabinet

PRODUCT RANGE

Maximum organization with  
Minimum space requirements.....  
The tools are always ready-to-hand.....

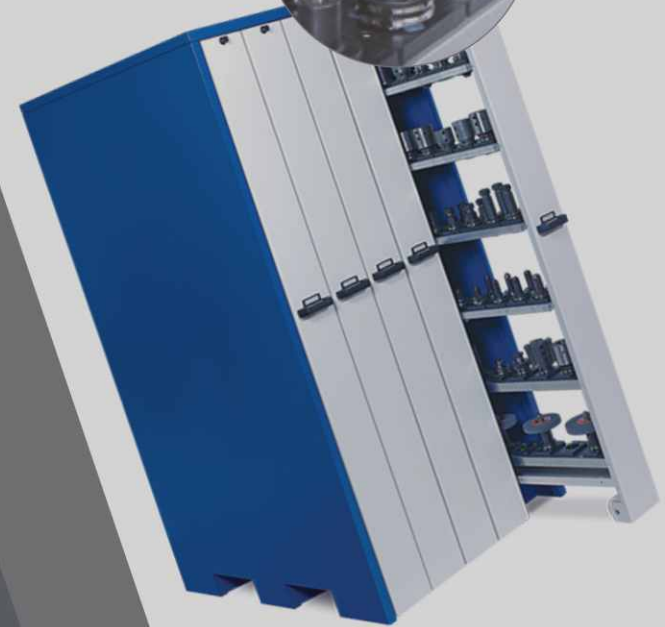

2018

## One for all!



Long Tools



CNC Tool

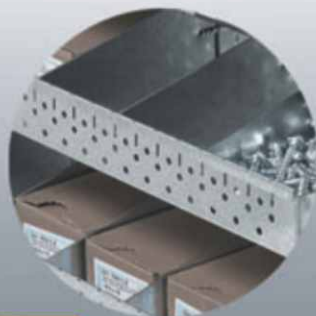

Hardware



Press-brake



Bin



1850mm H.

1250mm H.



Punching Tool



Hardware



Fastner



Die



**CNC Tools Cabinet**

Safe, functional technology made in India

The RKSS tool cabinets of the VDC series assure maximum organization at minimum space requirements. Thanks to vertical drawers, the tools are always ready-to-hand.

The direct access to the tooling from both sides provides increased safety as reaching over the tools is eliminated.

Integrated transport notches allow the easy relocation of your tool cabinet by lift truck or cart when empty.



**05 & 06**



**Colour Option**

**07**



Reduce your setup times with RKSS!

RKSS tool cabinets for milling and turning tools store up all common types of CNC tooling in a clean, safe and gentle way.

A unique tool retainer system with plastic reduction hooks allows optimal arrangement and fast access.

Our screwed tool carriers are equipped with coloured reduction hooks for each tool type such as BT, ISO, CAT, SK, HSK, VDI.

The flexible construction guarantees an easy and fast exchange of hooks and tool retainers.



1250mm H. X 1100mm D.



1850mm H. X 1100mm D.



Max. load capacity 900kg. each drawer



Relocation by pallet truck  
**only use for empty cabinet**



Drawers individually lockable

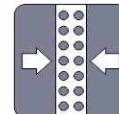

Both - sided access



Highest Capacity and reliable guidance the statements by idler wheels



Excerpts separately lockable and with easy to identify labeling field

Direct access to the tooling from both sides provides increased safety as reaching over the tools is eliminated.

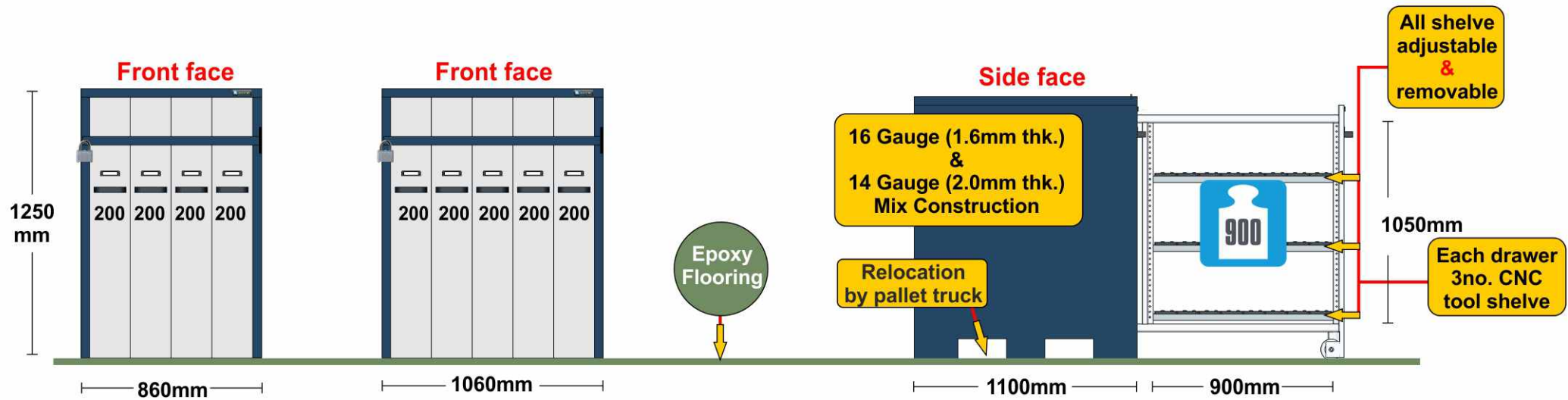

**RK VD CNC 1250-255-01**

200mm Wide - 4no. Drawers

**CNC Tool Carrier Storage Cap.**

**BT/ISO/CAT/SK-40 OR HSK-50A/63A OR C6 OR VDI-30/40**  
36 Tool Storage in 1 drawer  
36 Tool X 4 drawer = 144 Tool storage

**OR**

**BT/ISO/CAT/SK-50 OR HSK-80A/100A OR C8/C10 OR VDI-50/60**  
24 Tool Storage in 1 drawer  
24 Tool X 4 drawer = 96 Tool storage

**RK VD CNC 1250-315-02**

200mm Wide - 5no. Drawers

**CNC Tool Carrier Storage Cap.**

**BT/ISO/CAT/SK-40 OR HSK-50A/63A OR C6 OR VDI-30/40**  
36 Tool Storage in 1 drawer  
36 Tool X 5 drawer = 180 Tool storage

**OR**

**BT/ISO/CAT/SK-50 OR HSK-80A/100A OR C8/C10 OR VDI-50/60**  
24 Tool Storage in 1 drawer  
24 Tool X 5 drawer = 120 Tool storage



**BT-40 & 50  
ISO-40 & 50  
CAT-40 & 50  
SK-40 & 50  
HSK-63A & 100A**



Direct access to the tooling from both sides provides increased safety as reaching over the tools is eliminated.

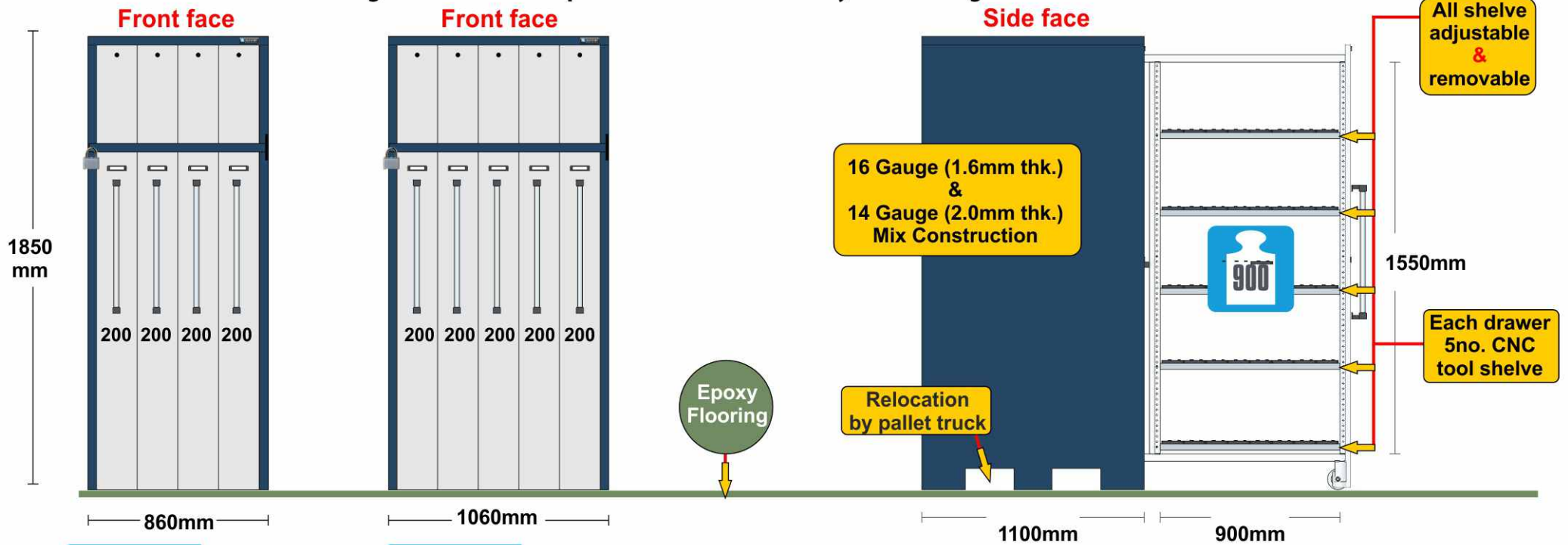

**RK VD CNC 1850-380-03**

**RK VD CNC 1850-466-04**

200mm Wide - 4no. Drawers

200mm Wide - 5no. Drawers

**CNC Tool Carrier Storage Cap.**

**CNC Tool Carrier Storage Cap.**

**BT/ISO/CAT/SK-40 OR HSK-50A/63A OR C6 OR VDI-30/40**

**BT/ISO/CAT/SK-40 OR HSK-50A/63A OR C6 OR VDI-30/40**

60 Tool Storage in 1 drawer  
60 Tool X 4 drawer = 240 Tool storage

360 Tool Storage in 1 drawer  
60 Tool X 5 drawer = 300 Tool storage

**OR**

**OR**

**BT/ISO/CAT/SK-50 OR HSK-80A/100A OR C8/C10 OR VDI-50/60**

**BT/ISO/CAT/SK-50 OR HSK-80A/100A OR C8/C10 OR VDI-50/60**

40 Tool Storage in 1 drawer  
40 Tool X 4 drawer = 160 Tool storage

40 Tool Storage in 1 drawer  
40 Tool X 5 drawer = 200 Tool storage

**BT-40 & 50  
ISO-40 & 50  
CAT-40 & 50  
SK-40 & 50  
HSK-63A & 100A**





## Standard Color option :

---



**7035**  
Pale Grey - Str.

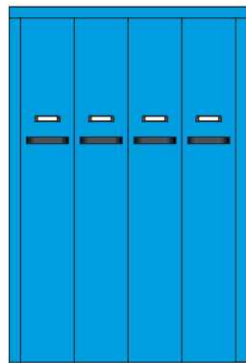

**5015**  
American Blue - Str.



**6009**  
D. A. Grey - Str.



**5013**  
PP Dark Grey - Str.



**3001**  
Red - Str.

Assembled components are transfer to pre-treatment plant for treating in 7 tank for degrees, zinc, phosphating and passivation.

Material received from pre-treatment department are immediately powder coated in the dust free painting booth and then the articles are put inside a baking oven at a temperature of 180° C for about 20 minutes.



**rk steel smith**  
defining workspace



Plot- B/32 (Part-2) Bileshwar Indl. Estate,  
Opp. G.V.M.M.,  
Odhav-Kathwada Road,  
Ahmedabad - 382415  
Gujarat (INDIA).



+91 94 281 35 100  
+91 98 253 00 059



rksteelsmith@gmail.com  
info@rksteelsmith.com  
sales@rksteelsmith.com



www.rksteelsmith.com