



rk steel smith
defining workspace

Industrial Vertical Drawer Special tools & Die Cabinet

PRODUCT RANGE

Maximum organization with
Minimum space requirements.....
The tools are always ready-to-hand.....



2018

One for all!



Long Tools



CNC Tool

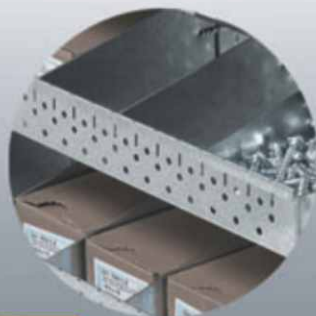

Hardware



Press-brake



Bin



1850mm H.

1250mm H.



Punching Tool



Hardware



Fastner



Die



Special tooling cabinet

05 & 06

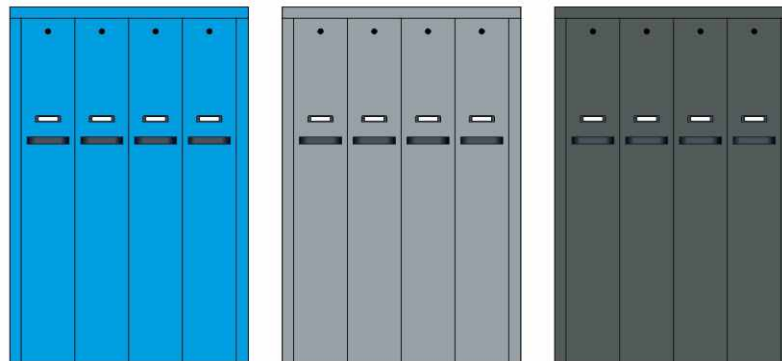

Colour Option

07

Due to the enormous payload you store heavy special tooling robust and safe.



1250mm H. X 1100mm D.



1850mm H. X 1100mm D.



Max. load capacity 900kg. each drawer



Relocation by pallet truck
only use for empty cabinet



Drawers individually lockable

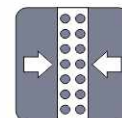

Both - sided access



Highest Capacity and reliable guidance the statements by idler wheels



Excerpts separately lockable and with easy to identify labeling field

Storage of Special tools

Direct access to the tooling from both sides provides increased safety as reaching over the tools is eliminated.

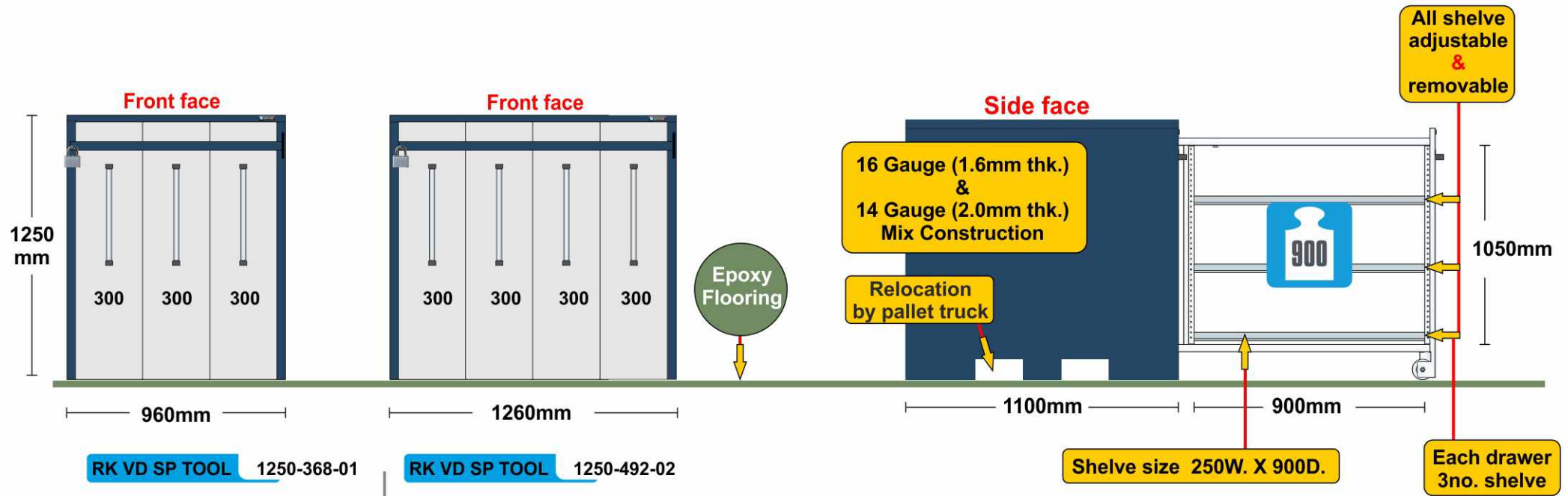

RK VD SP TOOL 1250-368-01

RK VD SP TOOL 1250-492-02

300mm Wide - 3no. Drawers

1no. drawer X 3no. shelves

3 Drawer X 3no. shelves = 09 shelves.

300mm Wide - 4no. Drawers

1no. drawer X 3no. shelves

4 Drawer X 3no. shelves = 12 shelves.



Storage of Special tools

Direct access to the tooling from both sides provides increased safety as reaching over the tools is eliminated.

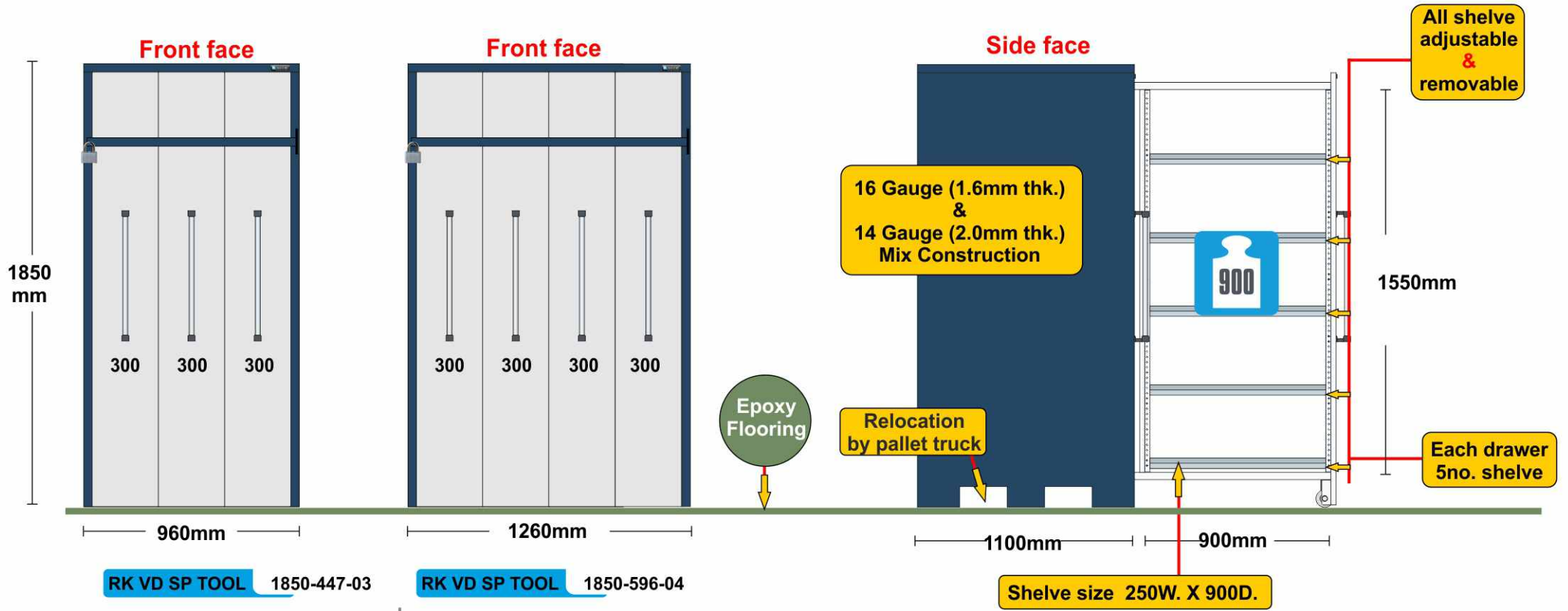

300mm Wide - 3no. Drawers

1no. drawer X 5no. shelves

3 Drawer X 5no. shelves = 15 shelves.

300mm Wide - 4no. Drawers

1no. drawer X 5no. shelves

4 Drawer X 5no. shelves = 20 shelves.



Standard Color option :



7035
Pale Grey - Str.

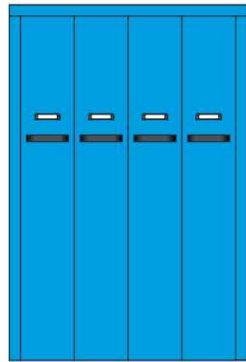

5015
American Blue - Str.



6009
D. A. Grey - Str.



5013
PP Dark Grey - Str.



3001
Red - Str.

Assembled components are transfer to pre-treatment plant for treating in 7 tank for degrees, zinc, phosphating and passivation.

Material received from pre-treatment department are immediately powder coated in the dust free painting booth and then the articles are put inside a baking oven at a temperature of 180° C for about 20 minutes.



rk steel smith
defining workspace



Plot- B/32 (Part-2) Bileshwar Indl. Estate,
Opp. G.V.M.M.,
Odhav-Kathwada Road,
Ahmedabad - 382415
Gujarat (INDIA).



+91 94 281 35 100
+91 98 253 00 059



rksteelsmith@gmail.com
info@rksteelsmith.com
sales@rksteelsmith.com



www.rksteelsmith.com